



**NZSV Series**

Multifunctional high-performance vector inverter

# **Instruction Manual**

Thank you for choosing us. NZSV series of multi-functional, high-performance vector frequency inverters.

Before installing, operating, maintaining, or inspecting the drive, please read this instruction manual carefully to fully utilize the drive's functions and ensure user safety.

In this instruction manual, safety is divided into two sections: Danger and Caution. Please pay special attention to the "  Warning " and "  Caution " symbols and related content.

"  Warning " Incorrect or erroneous operation may result in harm, potentially leading to death or serious injury.

"  Caution " is advised that incorrect or erroneous operation may cause harm, potentially resulting in personal injury or malfunction of the drive and mechanical systems. Depending on the circumstances, the precautions may also lead to serious consequences.

The illustrations in this instruction manual are for illustrative purposes only and may differ slightly from the actual product. Due to product upgrades, there may also be slight differences. Please refer to the actual product.

Please ensure this instruction manual is delivered to the end user and kept safe for future inspection and maintenance. If you have any questions, please contact the our company or our agent promptly; we are happy to assist you.

Change date	Change Notes
May 2024. 14	Increase 45 KW -- 110 KW Main circuit terminal diagram
April 7, 2025	Update 45-160 KW size

## 1 . Safety Precautions

Read this instruction manual carefully before installing, operating, maintaining, or inspecting .

The safety precautions in the instruction manual are categorized as " Warnings " or " Caution " .



It points out potential dangers that, if not avoided, could lead to personal injury or death.

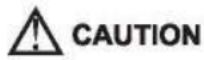

This indicates potential hazards that, if not avoided, could result in minor to moderate personal injury and equipment damage. It can also be used to warn against unsafe practices.

In some cases, even the precautions mentioned above can lead to serious accidents. Therefore, it is essential to follow these important precautions in all circumstances.

★ **Note** Steps taken to ensure correct operation.

Warning labels are displayed on the front cover of the drive unit.

Follow these guidelines when using the driver.

#### **Warning Mark**

<b>DANGER</b>
Risk of Injury and electric shock . Read the manual and follow the safety instruction before use . ·Isolate from supply and wait 10minutes before removing his cover. ·Ensure proper earth connection. Mount the inverter on a non - combustible surface .

## 2 .Unpacking and inspection

 <b>CAUTION</b>
• Do not install or run any drives that are damaged or have faulty parts, as this could result in injury.

After unpacking and removing the drive, please check the following items.

- ①. Confirm that the drive has not been damaged during transportation (damage or nicks on the body ).
- ②. Confirm that the package contains an instruction manual and warranty card.
- ③. Check the drive nameplate and confirm that it is the product you ordered.
  
- ④. If you ordered optional accessories for the drive, please confirm that the received accessories are what you need . If you find the drive or optional accessories to be damaged, please call your local dealer immediately.

### 3. Disassembly and Installation Warnings



- The design, installation, commissioning, and operation of the equipment must be carried out by trained and qualified professionals ; all provisions in the " Warnings " must be followed during the work process , otherwise serious personal injury or major property damage may occur.
- Input power cords are only allowed to be permanently and securely connected, and the equipment must be reliably grounded.
- Even when the driver is not in operation, the following terminals may still carry dangerous voltage:
  - Power terminals R , S, T
  - Terminals for connecting the motor U, V, W
- After the power switch is turned off, you must wait Installation can only begin after at least 10 minutes , and once the driver has completely discharged.
- The minimum cross-sectional area of the grounding conductor must be at least 10 mm<sup>2</sup>, or the value in the table below must be the maximum value.

power line conductor cross-sectional area	Cross-sectional area of grounding conductor
$S \leq 6$	S
$16 < S \leq 35$	16
$35 < S$	S/2

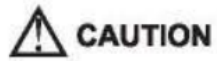

- When lifting the cabinet using the support base, do not grab the panel to lift it while moving the drive unit , otherwise the main unit may fall and cause personal injury.
- The drive unit should be installed on a flame-retardant material such as metal, away from heat sources and flammable objects.To prevent a fire.
- When installing two or more drives in a single cabinet, a cooling fan must be installed and the air temperature must be controlled below 40 °C.,  
Otherwise, overheating may cause a fire or damage to the equipment.

# Chapter 1 Overview

## 1-1 Inverter Nameplate Description

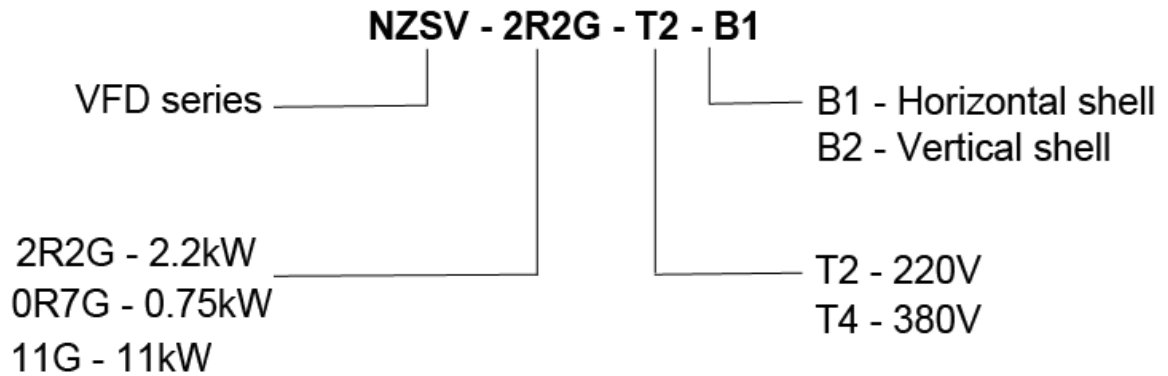
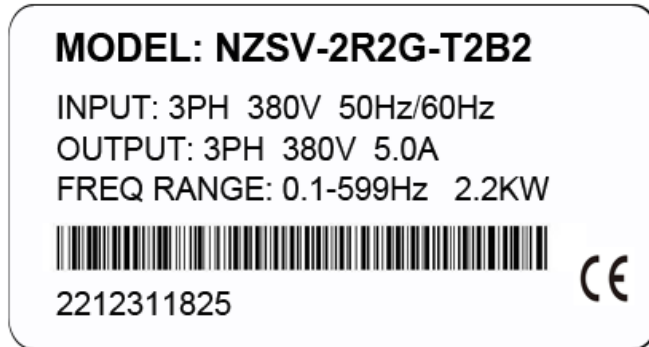

# 1-2 Comprehensive Technical Characteristics of Frequency Converters

Project		Specification
Basic Function	Control method	V/F control Open-loop vector control (without PG)
	Highest frequency	V/F: 0~3200 Hz Open-loop vector: 0~320 Hz
	Carrier frequency	0.5kHz ~ 16kHz It can automatically adjust the carrier frequency according to the load characteristics.
	Input frequency resolution	Digital setting: 0.01Hz Simulation settings: Maximum frequency × 0.025%
	Starting torque	G Type : 0.5Hz/150% (without PG); P Type: 0.5Hz/100%
	Speed range	1 : 100 ( No PG )
	Speed stability	±0.5% ( without PG )
	Overload capacity	Type G : 150% rated current for 60 s ; 180% rated current for 3 s . Type P: 120% rated current for 60 s ; 150% rated current for 3 s .
	Torque boost	since Dynamic torque increased; manual torque increased by 0.1%~30.0%.
	V/F curve	3 types: linear; multi-point; Nth power V/F curve ( 1.2 , 1.4 , 1.6 , 1.8 , 2 )
	V/F separation	Two methods: Full separation and partial separation
	Acceleration/deceleration curves	Linear or S-curve acceleration/deceleration methods. Four acceleration/deceleration times, ranging from 0.0 to 6500.0 s.
	DC braking	DC braking frequency: 0.00Hz ~ maximum frequency Braking time: 0.0s~36.0s; Braking current: 0.0%~100.0%
	Jog control	Jogging frequency range: 0.00Hz~50.00Hz . The acceleration/deceleration time is 0.0s to 6500.0s .
	Simple PLC , multi-speed operation	16 speed settings can be achieved via built-in PLC or control terminals.
	Built-in PID	It can easily realize a closed-loop control system for process control.
	Automatic Voltage Regulator ( AVR )	It can automatically maintain a constant output voltage when the mains voltage changes.
	Overvoltage and overcurrent speed control	Automatic current and voltage limiting during operation to prevent frequent overcurrent and overvoltage tripping.
Fast rate limiting function	Minimize overcurrent faults and protect the inverter for normal operation.	
Torque Limiting and Control	" excavator " feature automatically limits torque during operation. Prevents frequent overcurrent tripping; closed-loop vector mode enables torque control.	
Personalization features	Excellent performance	Asynchronous motor control achieved using high-performance current vector control technology.
	Instantaneous stop	During a momentary power outage, the voltage drop is compensated by load feedback energy to maintain the inverter's operation. Continue to run for a short period of time
	Fast rate limiting	To avoid frequent overcurrent faults in the frequency converter
	Timed control	Timer control function: Set time range 0.0 Min ~ 6500.0 Min
	Communication methods supported	RS - 485
Operation	Command source	Operation panel settings, control terminal settings, serial communication port settings. It can be switched in multiple ways
	frequency source	10 frequency sources: digital setpoint, analog voltage setpoint, analog current setpoint, Pulse-based or serial port-based input. Switchable in multiple modes.
	Auxiliary frequency	10 auxiliary frequency sources. Allows for flexible auxiliary frequency

	source	fine-tuning and frequency synthesis.
	Input terminal row	standard: 6 digital input terminals, with S3 supporting high-speed pulse input up to 100kHz (optional). 2 analog input terminals: one supports 0-10V voltage input only , and the other supports either 0-10V voltage input or 4-20mA current input .
	Output terminals	1 high-speed pulse output (optional) and collector output terminal 1 relay output terminal 1 analog output terminal supports 4 ~20mA current output or 0~10V voltage output.
Display and Keyboard Operation	LED display	Display parameters
	Button lock and function selection	This allows for partial or complete locking of buttons, defining the active range of certain buttons to prevent accidental operation.
	Protection function	Features include: motor short circuit detection, input/output phase loss protection, overcurrent protection, overvoltage protection, undervoltage protection, overheat protection, and overload protection.
Environment	Location of use	Indoors, away from direct sunlight, free from dust, corrosive gases, flammable gases, and oil. Fog, water vapor, dripping water, or salt, etc.
	Altitude	Less than 1000m
	Ambient temperature	-10 °C ~ + 40 °C ( Please reduce the rated capacity if the ambient temperature is between 40 °C and 50 °C)
	humidity	Less than 95% RH , no water droplets condense.
	vibration	Less than 5.9 m/s <sup>2</sup> ( 0.6 g )
	Storage temperature	-20 °C ~ + 60 °C
	Protection level	IP65 for power consumption below 3.7KW, IP54 for power consumption of 3.7KW and above.

## 1-3 series frequency converter models

Inverter Model	Enter Voltage	Rated output power ( kW )	Rated input current ( A )	Rated output current ( A )	Motor adapter (KW)
NZSV-0R7G-T2-B1	1PH AC220V ±15%	0.75	7.2	3.8	0.75
NZSV-1R5G-T2-B1		1.5	10	7.2	1.5
NZSV-2R2G-T2-B1		2.2	16	9.0	2.2
NZSV-0R7G-T4-B1 (2)	3PH AC380V±15%	0.75	3.8	2.1	0.75
NZSV-1R5G-T4-B1 (2)		1.5	5	3.8	1.5
NZSV-2R2G-T4-B1 (2)		2.2	5.8	5.1	2.2
NZSV-3R7G-T4-B1 (2)		3.7	10.0	9.0	3.7
NZSV-5R5G-T4-B1 (2)		5.5	15.0	13.0	5.5
NZSV-7R5G-T4-B1 (2)		7.5	20.0	17.0	7.5
NZSV-11G-T4-B2		11	26.0	25.0	11
NZSV-15G-T4-B2		15	35.0	32.0	15
NZSV-18.5G-T4-B2		18.5	38.0	37.0	18.5
NZSV-22G-T4-B2		22	46.0	45.0	22
NZSV-30G-T4-B2		30	62	60	30
NZSV-37G-T4-B2		37	76	75	37
NZSV-45G-T4-B2		45	92	90	45
NZSV-55G-T4-B2		55	113	110	55
NZSV-75G-T4-B2		75	157	150	75
NZSV-90G-T4-B2		90	180	176	90
NZSV-110G-T4-B2		110	214	210	110
NZSV-132G-T4-B2		132	256	253	132
NZSV-160G-T4-B2	160	307	300	160	

# Chapter 2 Inverter installation and wiring

## 2-1 Installation Environment and Requirements

The installation environment of a frequency converter has a direct impact on its service life and normal operation. Using a frequency converter in an environment that does not comply with the instructions may cause it to activate protection or malfunction.

NZSV This series of frequency converters are wall-mounted; please install them vertically to facilitate airflow and improve heat dissipation. Please ensure the installation environment for the frequency converter meets the requirements.

(01) Ambient temperature  $-10\text{ }^{\circ}\text{C}$  to  $+40\text{ }^{\circ}\text{C}$

(02) Ambient humidity 0-95 % and no condensation

(03) Avoid direct sunlight

(04) The environment does not contain corrosive gases or liquids.

(05) The environment is free of dust, floating fibers, lint, and metal particles.

(06) Keep away from radioactive materials and flammable materials

(07) Keep away from sources of electromagnetic interference ( such as welding machines and high-powered machinery ).

(08) The mounting surface should be firm and free from vibration. If vibration cannot be avoided, please install anti-vibration pads to reduce vibration.

(09) Please install the frequency converter in a well-ventilated location that is easy to inspect and maintain , and install it on a sturdy, non-combustible material, away from heat sources ( such as braking resistors ).

(10) For altitudes below 1,000 meters (in areas above 1,000 meters, the frequency converter must be used at a lower speed).

(11) Please reserve sufficient space when installing frequency converters, especially when installing multiple frequency converters. Please pay attention to the placement of the frequency converters and add a hot air fan to keep the ambient temperature below  $45\text{ }^{\circ}\text{C}$ .

① Installation of a single frequency converter:

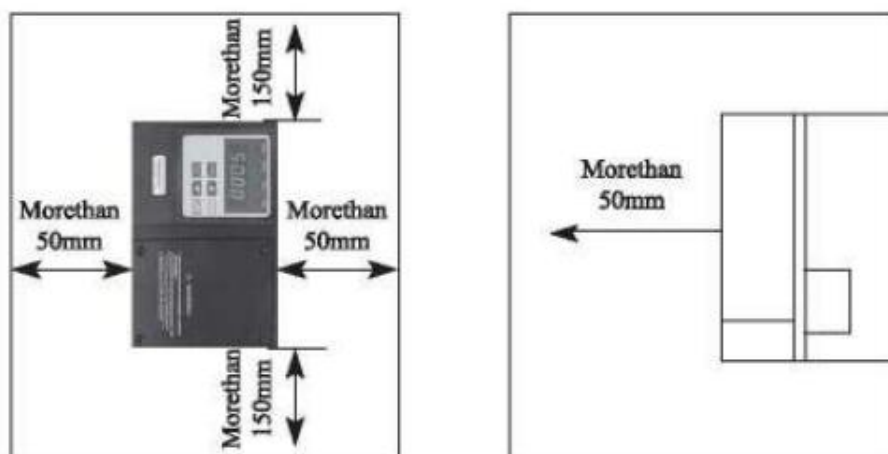

② Multiple frequency converters are installed in the same control cabinet. Please note:

(1) During installation, frequency converters should be placed side by side as much as possible.

**Better installation method**



**Poor installation method**

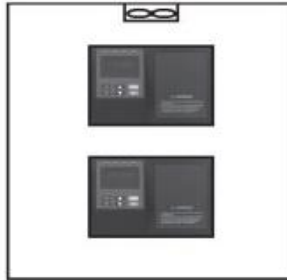

(2) When multiple frequency converters are installed in the same control cabinet, ensure sufficient space and pay attention to air convection inside the cabinet, as well as the installation of cooling fans.

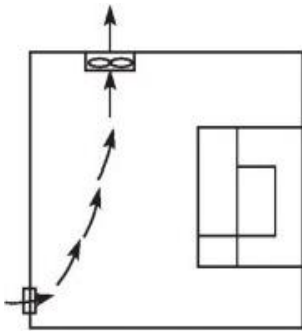

**Incorrect installed position of the fans**

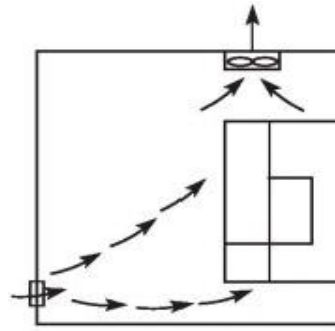

**Correct installation position of the fans**

(12) Variable frequency drive (VFD) shape and installation dimensions

a. Horizontal installation outline drawing

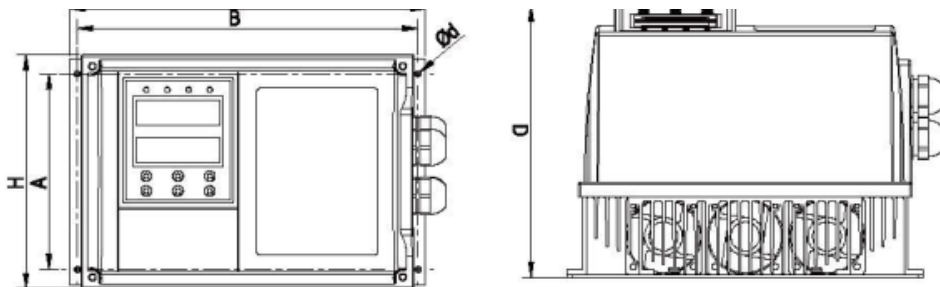

Model	Outline dimensions ( mm )			Installation dimensions ( mm )		
	W	H	D	A	B	Φd
NZSV-0R7G-T2-B1	188	122	134	105	178	4
NZSV-1R5G-T2-B1						
NZSV-2R2G-T2-B1						
NZSV-0R7G-T4-B1						
NZSV-1R5G-T4-B1						
NZSV-2R2G-T4-B1						
NZSV-3R7G-T4-B1	235	154	179	129	225	4
NZSV-5R5G-T4-B1						
NZSV-7R5G-T4-B1						

b. Vertical installation outline drawing

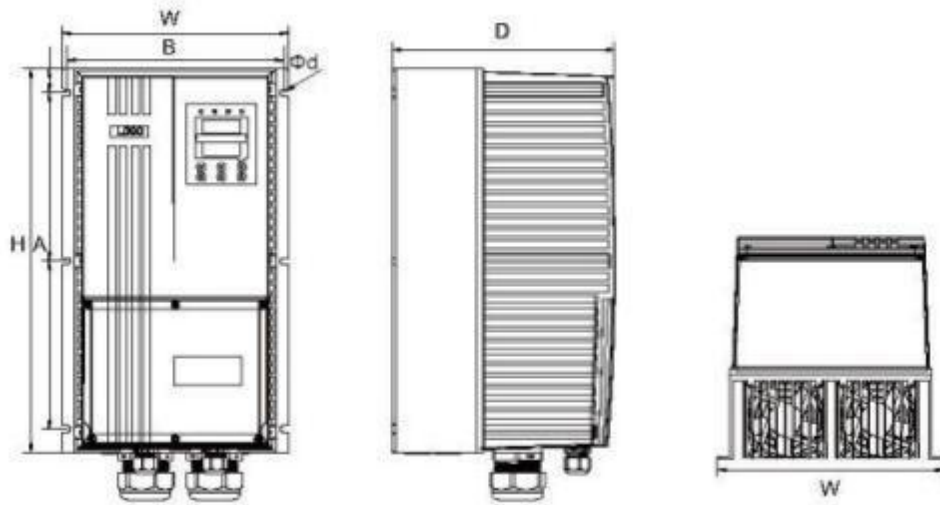

Model	Outline dimensions ( mm )			Installation dimensions ( mm )		
	W	H	D	A	B	Φd
NZSV-0R7G-T2-B2	140	190	138	160	130	4.5
NZSV-1R5G-T2-B2						
NZSV-0R7G-T4-B2						
NZSV-1R5G-T4-B2						
NZSV-2R2G-T4-B2	192	280	178	200	180	5.5
NZSV-3R7G-T4-B2						
NZSV-5R5G-T4-B2						
NZSV-7R5G-T4-B2						
NZSV-11G-T4-B2						
NZSV-15G-T4-B2	236	300	204	250	225	7
NZSV-18G-T4-B2						
NZSV-22G-T4-B2						
NZSV-30G-T4-B2	236	400	231	175+175	225	7
NZSV-37G-T4-B2						

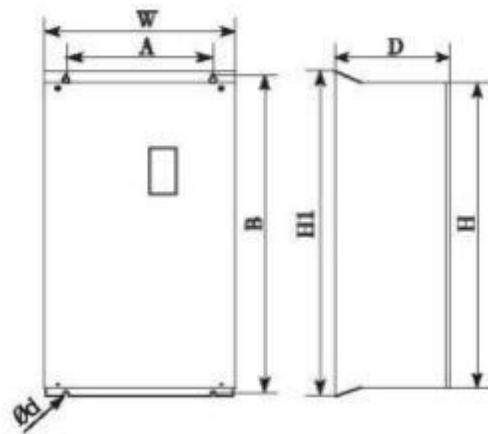

Model	Outline dimensions ( mm )				Installation dimensions ( mm )		
	W	H	H1	D	A	B	$\Phi d$
NZSV-45G-T4-B2	300	450	482	293	210	465	9
NZSV-55G-T4-B2							
NZSV-75G-T4-B2	400	628	668	275	300	643	9
NZSV-90G-T4-B2							
NZSV-110G-T4-B2							
NZSV-132G-T4-B2	400	860	900	321.5	330	876	11
NZSV-160G-T4-B2							

## 2-2 Inverter Wiring

The wiring of a frequency converter is divided into the main circuit section and the control section.

### 2-2-1 Main circuit wiring

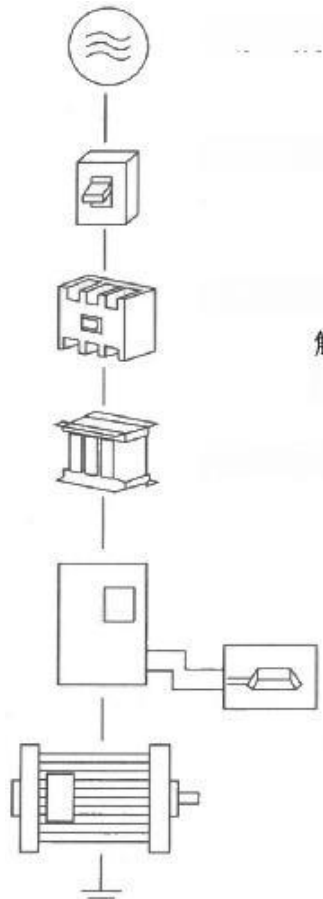

**Power supply** : Please use a power supply within the specifications allowed by the frequency converter.

**Circuit breaker** : When a fuseless circuit breaker (MCCB) or a residual current circuit breaker is used, a large inrush current flows into the frequency converter when power is switched on. Please pay attention to the selection of the circuit breaker.

**Contactor** : Electromagnetic contactor ( MC ),  
Note: Do not use electromagnetic connections to start and stop the frequency converter; otherwise, the frequency will decrease the lifespan of the device.

**AC reactor** : Optional, suppresses high harmonics and improves power factor.  
Please select.  
Choose a suitable reactor .

**Braking resistor** : can improve the braking effect of the built-in brake in the frequency converter. Mobility .

## 2-2-2 Peripheral Component Description

### (1) AC power supply

Please use the power supply specified in the instruction manual.

### (2) Fuseless Circuit Breaker ( MCCB )

When the power supply voltage is too low or there is a short circuit on the input side, the circuit breaker can provide protection. When inspecting, maintaining, or not working, the circuit breaker can be disconnected to isolate the frequency converter from the power supply.

### (3) Electromagnetic contactor ( MC )

It facilitates the control of the inverter's power-on and power-off, ensuring safety.

### (4) AC reactor

a: Suppress high harmonics and protect the frequency converter.

b: Improve power factor

### (5) Braking resistor

When the motor is braking, to prevent excessive voltage in the inverter's DC circuit and improve the braking capacity of the built-in braking unit, the braking resistor connection method for the Z 5 000 series inverter is as follows:

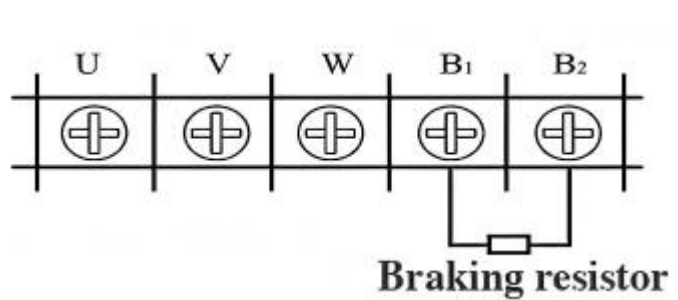

## 2-2-3 Main Circuit Wiring Precautions

(1) Wiring specifications: Please implement wiring in accordance with electrical regulations ;

(2) Do not connect AC power to the output terminals (U, V, W ) of the frequency converter, otherwise it will damage the frequency converter;

(3) For power wiring, please use isolated wires and conduits as much as possible, and ground both ends of the isolated wires or conduits;

(4) The inverter grounding wire must not be grounded together with the welding machine, high-power motor or high-current load; please ground it separately.

(5) Grounding terminal E: Grounding impedance is less than 100Ω;

(6) When using the grounding wire, please use it in accordance with the specifications specified in the electrical equipment technical specifications. The shorter the grounding wire, the better.

(7) When multiple frequency converters are grounded, please be careful not to create a grounding loop, as shown in the figure below;

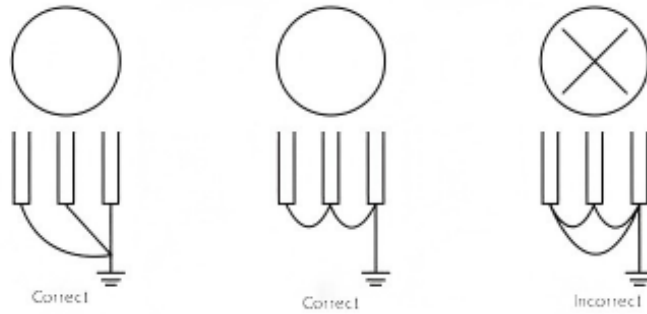

(8) The main circuit power lines and control lines must be wired separately, and parallel wiring must be spaced out. 10 cm. In addition, cross wiring should be perpendicular to each other. Do not place control lines and power lines in the same cable tray, otherwise it will cause interference.

(9) Under normal circumstances, the distance between the frequency converter and the motor should be less than 30m. If the distance between the inverter and the motor is too long, the inrush current generated by the parasitic capacitance may trigger the over-current protection, potentially causing malfunctions. This could lead to inverter failure or abnormal equipment operation. The maximum distance between the inverter and the motor should not exceed [number missing]. 100m. For distances of several meters or longer, please select an output-side filter and reduce the carrier frequency.

(10) No absorption capacitors or other RC absorption devices shall be installed on the output side (U, V, W) of the frequency converter;

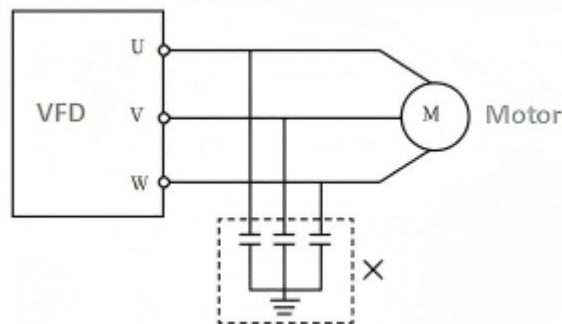

(11) Please ensure that all main circuit terminals are tightened and that the leads are in good contact with the terminals to prevent loosening due to vibration, which could generate sparks and cause a short circuit.;

(12) To reduce interference, it is recommended to connect surge absorbers to the coils of electromagnetic contactors, relays and other devices in the circuit around the frequency converter .

### 2-2-4 Recommended specifications for the device

Inverter Model	Enter Voltage	Motor used (KW)	Main return path (mm <sup>2</sup> )	Air circuit breaker (A)	Electromagnetic contactor (A)
NZSV-0R7G-T2-B1	1PH 220V ±15%	0.75	0.75	16	12
NZSV-1R5G-T2-B1		1.5	1.5	25	18
NZSV-2R2G-T2-B1		2.2	2.5	32	25
NZSV-0R7G-T4-B1 (2)	3PH 380V ±15%	0.75	0.75	6	9
NZSV-1R5G-T4-B1 (2)		1.5	0.75	10	9
NZSV-2R2G-T4-B1 (2)		2.2	0.75	10	9
NZSV-3R7G-T4-B1 (2)		3.7	1.5	16	12
NZSV-5R5G-T4-B1 (2)		5.5	2.5	20	18
NZSV-7R5G-T4-B1 (2)		7.5	4	32	25
NZSV-11G-T4-B2		11	4	40	32
NZSV-15G-T4-B2		15	6	50	38
NZSV-18.5G-T4-B2		18.5	10	50	40
NZSV-22G-T4-B2		22	10	63	50
NZSV-30G-T4-B2		30	16	100	65
NZSV-37G-T4-B2		37	25	100	80
NZSV-45G-T4-B2		45	35	160	95
NZSV-55G-T4-B2		55	50	160	115
NZSV-75G-T4-B2		75	70	250	150
NZSV-90G-T4-B2		90	95	250	170
NZSV-110G-T4-B2		110	120	400	205
NZSV-132G-T4-B2	132	150	400	245	
NZSV-160G-T4-B2	160	185	400	300	

\*The data in the table above is for reference only.

### 2-2-5 Main Circuit Terminals and Instructions

Users can open the top cover of the frequency converter to see the main circuit terminals. 37 KW Standard configuration below includes built-in EMC Filtering and built-in braking unit, 45 KW The above models are equipped with an internal braking unit, or an external braking unit.

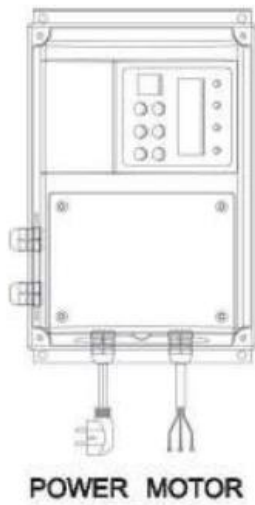

Note: The illustrations are for illustrative purposes only and may differ from the products you order. Please refer to the actual product.

1 Main circuit terminal description

220V 0.75-2.2 KW - Horizontal schematic diagram:

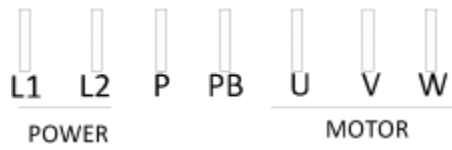

380V 0.75-5.5 KW - Horizontal schematic diagram:

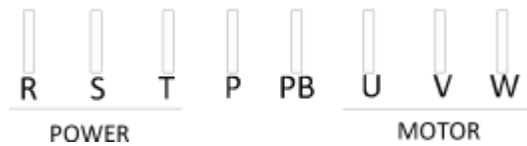

380V 7.5KW - Horizontal schematic diagram:



220V 0.75-2.2 KW - Vertical schematic diagram:

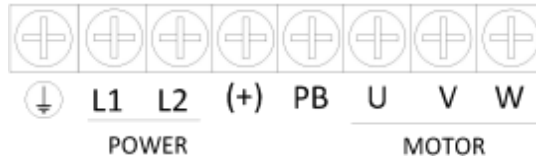

380V 0.75-7.5 KW - Vertical schematic diagram:

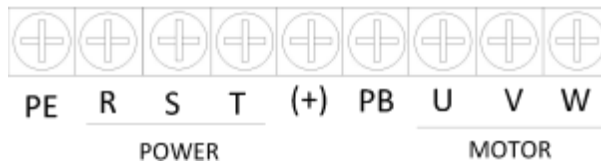

380V 11 KW - 15 KW -- Vertical schematic diagram:

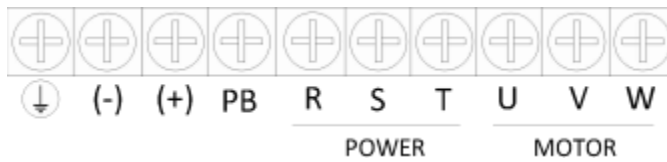

380V 18.5 KW - 22 KW Schematic diagram:



380V 30 KW --37 KW Schematic diagram:

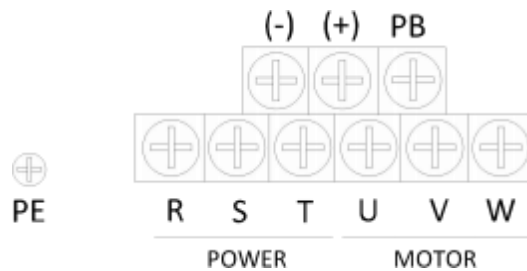

380V 45 KW --110 KW Schematic diagram:

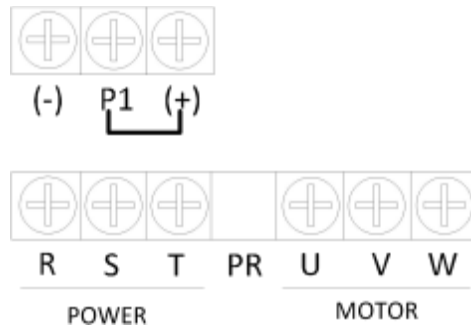

380V 132 KW -- 160 KW Schematic diagram:

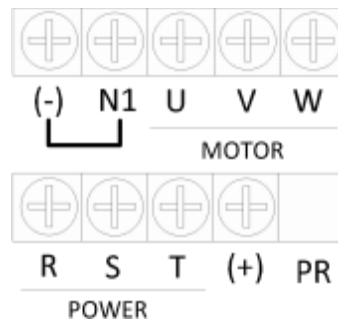

Name	Function Description
PE	Grounding terminal
R, S, T	Power input terminal
L1, L2	
U, V, W	Connect to a three-phase AC current motor
+、 PB	Braking resistor terminals
+、 PR	
P, PB	
+、 -	The inverter's DC positive and negative terminals can be connected to a braking unit.
+、 P1	After removing the shorting link, a DC reactor can be connected.
-、 N1	

2.Wiring example

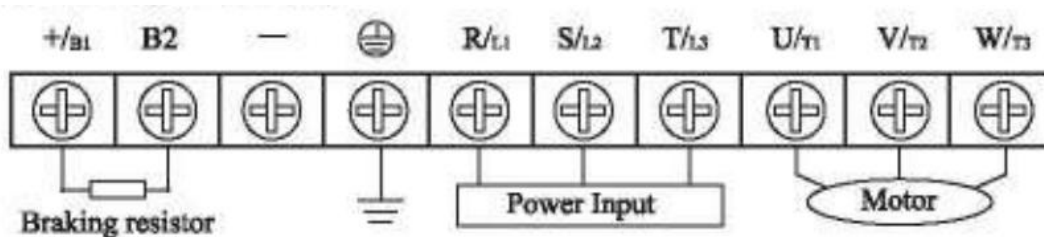

### 3. Basic wiring diagram

#### ① Standard

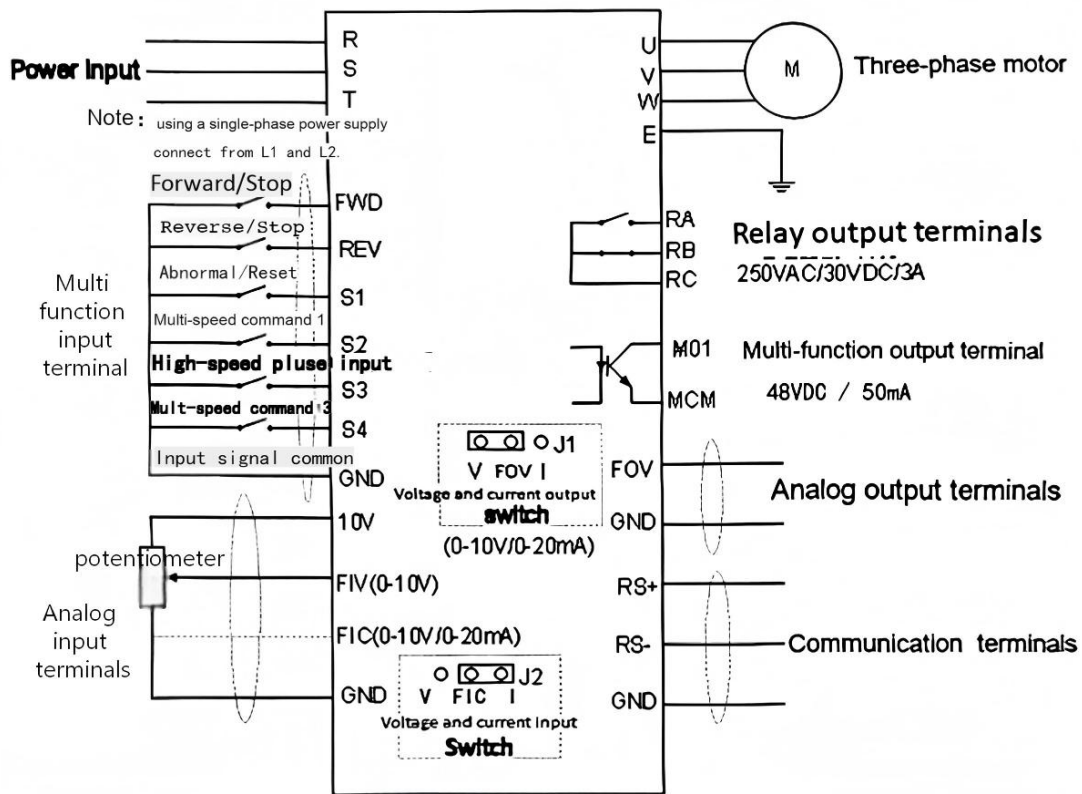

② Special Edition

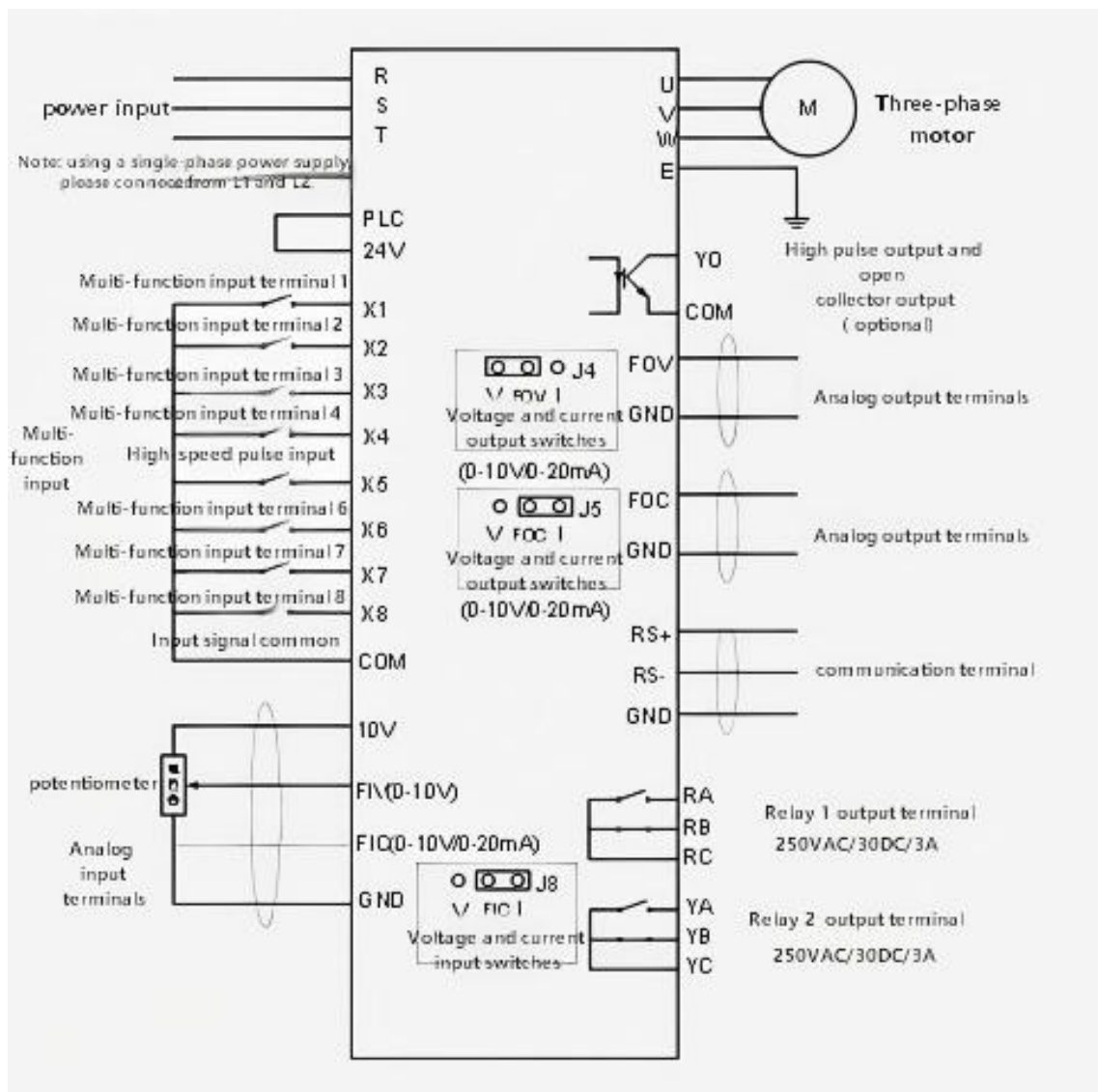

## 2-3 Control terminals

### a. Control terminal arrangement (standard)



### Control Terminal Description

Terminal Name	Function description	Remark
FWD	Forward rotation command input terminal (multi-function input terminal)	Multi-function input terminal S1~S4, FWD , REV Terminals can be accessed via parameters Number P315~P320 specific Settings, setting terminals and GND Effective when closed
REV	Reverse command input terminal (multi-function input terminal)	
S1	Fault Reset	
S2	Multi-speed instructions 1	
S3	Multi-speed instructions 2 (High-speed pulse input)	
S4	Multi-speed instructions 3	
FOV	Analog voltage output terminals	0~10V
10V	Frequency setting power supply	
FIV	Analog voltage command input terminal	0~10V
FIC	Analog current command input terminal	0~20 mA
GND	Input signal common terminal	
MCM	Optical coupling output common terminal	
MO1	Multifunctional Optical Coupler Output Contact	
RA	Relay output contact (normally open)	
RB	Relay output contact (normally closed)	
RC	Relay output contacts RA , RB Public terminal	

**Control panel switch instructions:**

Switch Name	Switch instructions
J1	V, FOV Shorting it provides voltage output; I, FOV Shorting enables current output.
J2	V, FIC Shorting is for voltage input; I, FIC Shorting is for current input

**b. Special Edition**

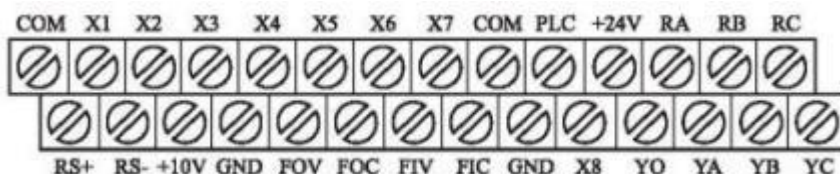

Terminal Name	Function description
X1	The digital input terminals form a bipolar optocoupler-isolated input. Input voltage : 9-30V; input impedance: 3.3kΩ.
X2	
X3	
X4	
X6	
X7	
X8	
X5	High-speed pulse or switch input, and PLC and COM This forms a bipolar optocoupler-isolated input. Pulse input frequency range: 0-50 kHz , input voltage range: 9-30V, input impedance: 1.1kΩ.Ω.
24V	24V Auxiliary power supply (current: 150 mA )
COM	24V and the common terminal of the switch quantity
FIV	Analog input, Voltage range: 0~10V, input impedance: 20kΩΩ
FIC	Analog input, voltage/current passing through J8 Optional input impedance: 10kΩΩ (voltage input ) / 500Ω (Current Input)
10V	10V Auxiliary power supply
GND	10V See zero potential (Note: COM) and GND (It is isolated)
YO	The high-speed pulse or open-collector output terminal corresponds to the common terminal. COM , output frequency range: 0-50 kHz
FOV , FOC	The analog output terminals can all be selected for current or voltage output via jumpers.
RA / RB / RC	Relay output, RC It's a public endpoint, RA It is normally open, RC It is normally closed; contact capacity: AC 250V/3A, DC 30V/1A
YA / YB / YC	Relay output, YC It's a public terminal, YA It is always on, YC It is normally closed; contact capacity: AC 250V/3A, DC 30V/1A
RS +/ RS -	485 Communication interface

**Control panel switch instructions:**

Switch Name	Switch instructions
J8	V, FIC Shorting is for voltage input; I, FIC Shorting is for current input
J14	V, FOV Shorting it provides voltage output; I, FOV Shorting enables current output.
J5	V, FOC Shorting it provides voltage output; I, FOC Shorting enables current output
JP 1/ JP 2	Anti-interference selection switch. When external interference is severe and affects the normal operation of the frequency converter, you can try closing this switch.

**2-4 Precautions for power distribution in control circuits:**

- (1) Please connect the control signal line to the main return line and other power lines. The power cords are routed separately.
- (2) To prevent malfunctions caused by interference, please use twisted shielded wire or double-strand shielded wire with a specification of 0.5–2 mm<sup>2</sup>.
- (3) Please determine the allowable conditions for each terminal, such as power supply, maximum allowable current, etc.
- (4) Grounding terminal E Please ground correctly; the grounding impedance should be less than 100Ω.
- (5) Wiring requirements for each terminal, and correct selection of accessories such as potentiometers, voltmeters, input power supplies, etc.
- (6) After completing the wiring, please check it correctly and power it on only after confirming that there are no errors.

# Chapter 3 Operation

## 3-1 Digital Operation Panel Instructions

The digital control panel is also called a keyboard.

### 3-1-1 Panel Diagram

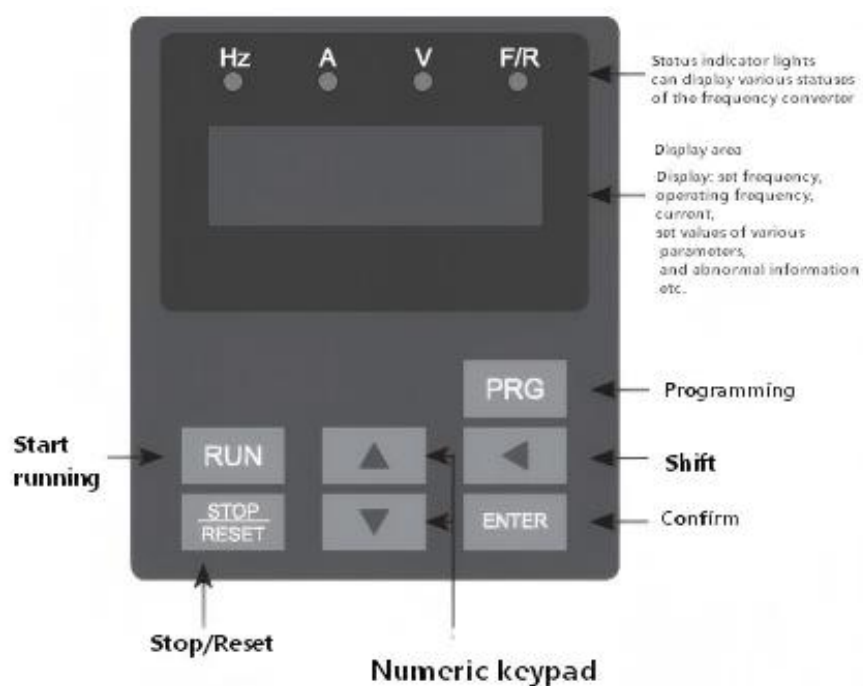

### 3-1-2 Button Function Description

Button Name	Name	Function Description
PRG	Programming key	Enter or exit via the first-level menu
ENTER	Confirm button	Enter the menu screen step by step, set the parameters and confirm.
▲	UP Increment key	Increment of data or function code
▼	DOWN Decrease key	Decreasing of data or function code
▶	shift key	In the shutdown and operation display interfaces, the displayed parameters can be cycled through; when modifying parameters, the modification digits can be selected .
RUN	Run key	In keyboard operation mode, it is used to perform operations.
STOP/RESET	Stop / Reset button	When running, pressing this key can stop the operation, subject to function codes. P7.02 It is not restricted by function codes; when a

		fault alarm is triggered, this key can be used to reset the fault, and is not affected by function codes.P7.02 limit.
--	--	---

### 3-1-3 Indicator Light Description

Indicator light name	Indicator light description
Hz	Frequency indicator light
A	Current indicator light
V	Voltage indicator light
FWD/REV	Forward/reverse indicator lights; A light off indicates that the rotation is in the forward direction, and a light on indicates that the rotation is in the reverse direction.
LOCAL	Control mode indicator light; An off light indicates keyboard control status, a flashing light indicates terminal control status, and an on light indicates communication control status.
FUNC/ERR	Alarm indicator light; An off light indicates that the inverter is in normal condition; a flashing light indicates that the inverter is in overload pre-alarm condition; and an on light indicates that the inverter is in fault condition.

## 3-2 Operating Procedures

### 3-2-1 Parameter Setting

The three-level menus are as follows:

1. Function code group number (first-level menu);
2. Function code number (second-level menu);
3. Function code setting value (third-level menu).

Note: When operating within a third-level menu, you can press PRG or ENTER R return to the second-level menu. The difference between the two is: Press ENTER Save the settings to the control panel, then return to the secondary menu and automatically move to the next function code; press PRG It will then return directly to the second-level menu, without storing parameters, and remain on the current function code.

For example: function codes P1.03 from 00.00 HzChange settings to 50.00 Hz .

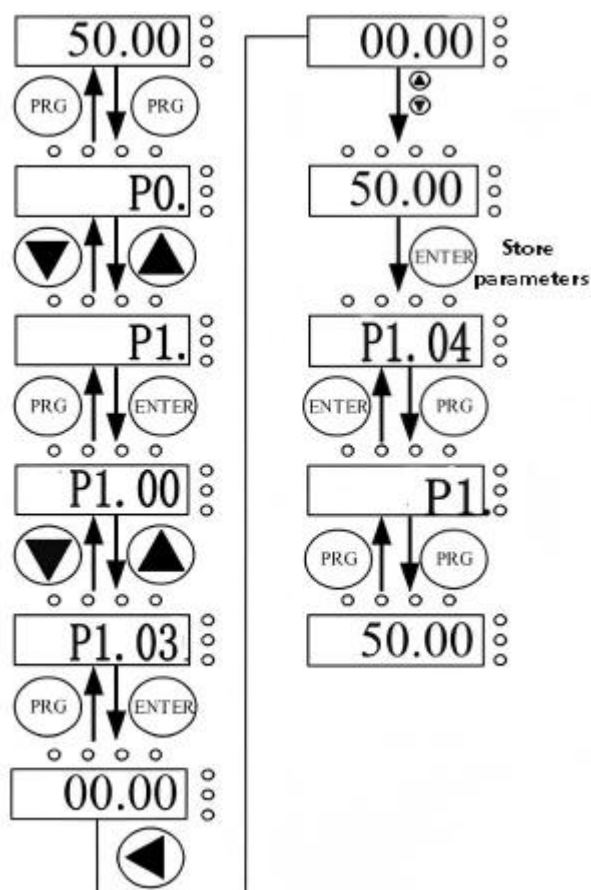

In the third-level menu state, if the parameter does not flash, it means that the function code cannot be modified. Possible reasons include:

- 1) This function code represents a parameter that cannot be modified, such as actual detection parameters or runtime record parameters.
- 2) This function code cannot be modified while the system is running; it can only be modified after the system is stopped.

### 3-2-2 Fault Reset

When a frequency converter malfunctions, it will display relevant fault information. Users can reset the fault using the STOP key on the keypad or the terminal function (P5 group). After a fault reset, the frequency converter will enter standby mode. If the frequency converter is in a faulty state and the user does not reset it, the frequency converter will enter a protection mode and will not be able to operate.

### 3-2-3 Motor parameter self-learning

#### 1: Comprehensive parameter self-learning

Select NonePG When operating in vector control mode, the motor's nameplate parameters must be accurately input. The inverter will then match the standard motor parameters based on these nameplate parameters. To obtain good control performance, it is recommended to perform motor parameter self-learning. The self-learning operation steps are as follows:

First, select the keyboard command channel (P0.02) as the run command channel.

Then please enter the following parameters according to the actual parameters of the motor:

P2.01: Motor rated power;

P2.02: Motor rated voltage;

P2.03: Motor rated current;

P2.04: Motor rated frequency;

P2.05: Rated speed of the motor.

**\*\*Note:** During the full parameter self-learning process, the motor must be disconnected from the load; otherwise, the motor parameters obtained through self-learning may be incorrect. \*\*

#### 2: Self-learning of static parameters

During the self-learning of motor static parameters, it is not necessary to disconnect the motor from the load. Before the self-learning, the parameters on the motor nameplate (P2.01-P2.05) must be entered correctly. After self-learning, the stator resistance, rotor resistance, and leakage inductance of the motor will be detected. However, the mutual inductance and no-load current of the motor cannot be measured; users can enter the corresponding values according to the motor nameplate.

## 3.3 Operating Status

### 3-3-1 Power-on initialization

During the inverter power-on process, the system first performs initialization, LED It displays as "2000" The indicator lights will illuminate, and the inverter will enter standby mode after initialization is complete.

### **3-3-2 standby**

In shutdown or running state, It can display a variety of status parameters. The display of a parameter can be selected by binary bits using function codes P7.03 and P7.04 (running parameters) and P7.05 (stop parameters). The definition of each bit is given in the description of function codes P7.03, P7.04 and P7.05.

### **3-3-3 Motor parameter self-learning**

Please refer to function code P2.37 for details explanation.

### **3-3-4 Operating**

In the running state, there are 29 status parameters that can be selected whether to be displayed. These include: operating frequency, set frequency, bus voltage, output voltage, output current, operating speed, output power, and output torque.

Whether to display is selected bitwise (converted to binary) by function codes P7.03 and P7.04.

Press  the keys to switch the selected parameters in sequence.

### **3-3-5 Fault**

NZSV The series of frequency converters provides various fault information; please refer to NZSV Series of frequency converter faults and their countermeasures.



# Chapter 4 Functional Parameter Summary

PP.00 set to a non-zero value to enable parameter protection password. In both function parameter mode and user-changeable parameter mode, the parameter menu can only be accessed after correctly entering the password. To disable the password, set PP.00 to 0. Groups P and C are basic function parameters, while group D is monitoring function parameters.

The symbols in the function table are explained as follows:

“ ☆ ” : This indicates that the setting value of this parameter can be changed whether the frequency converter is in a stopped or running state;

“ ★ ” : This indicates that the setting of this parameter cannot be changed when the frequency converter is running;

" ● " This indicates that the value of this parameter is the actual recorded value and cannot be changed;

“ \* ” This indicates that the parameter is a " manufacturer parameter " . This setting is limited to the manufacturer and is not to be operated by users.

Basic Functional Parameter Summary:

Function code	Name	Set range	Factory value	Change
P0 Basic Function Group				
P0.00	G/P type display	1 :GType (constant torque load model) 2 : P Type (fan, pump, and other load models)	Model confirmed	★
P0.01	Control mode selection	0 V /F control 1 :nonePG ( speed sensor ) vector control	0	★
P0.02	Command source selection	0: Keyboard Command Channel (LED off) 1: Terminal Command Channel (LED on) 2: Communication Command Channel (LED flashing)	0	☆
P0.03	Frequency source superposition selection	Units: Frequency Source Selection 0: Primary Frequency Source X 1: Primary-Secondary Operation Result (Operation relationship determined by tens digit) 2: Switch between Primary Frequency Source X and Secondary Frequency Source Y 3: Switch between primary frequency source X and primary-secondary calculation result 4: Switch between secondary frequency source Y and primary-secondary calculation result	00	☆

		Tens digit: Primary-secondary calculation relationship for frequency sources 0: Primary + Secondary 1: Primary - Secondary 2: Maximum value of both 3: Minimum value of both		
P0.04	Main frequency sourceX choice	0: Digital setting (preset frequency P0.10, modifiable via UP/DOWN, no power-off memory) 1: Digital setting (preset frequency P0.10, modifiable via UP/DOWN, power-off memory) 2: FIV 3: FIC 4: Keyboard Encoder 5: PULSE Setting (S3) 6: Multi-Step Command 7: Simple PLC 8: PID 9: Communication Setpoint	0	★
P0.05	Auxiliary frequency sourceY choose	same P0.04 (Main frequency source)X choose)	0	★
P0.06	Auxiliary frequency source during superposition Y range selection	0: relative to the maximum frequency 1: Relative to the frequency sourceX	0	☆
P0.07	Auxiliary frequency source during superposition Y range	0%~150%	100%	☆
P0.08	Acceleration time 1	0.00s~6500.0s	Model confirmed	☆
P0.09	Deceleration	0.00s~6500.0s	Model	☆

	time 1		confirmed	
P0.10	Preset frequency	0.00 Hz ~ Maximum frequency (P0.12)	50.00 Hz	☆
P0.11	Direction of movement	0: Same direction 1: Opposite direction	0	☆
P0.12	Maximum frequency	50.00 Hz ~ 320.00 Hz	50.00 Hz	★
P0.13	Upper limit frequency source	0: P0.12 set up 1: FIV 2: FIC 3: Retain 4: PULSE Pulse setting 5: Communication given	0	★
P0.14	Upper limit frequency	Lower limit frequency P0.16 ~ Maximum frequency P0.12	50.00 Hz	☆
P0.25	Runtime frequency commands UP / DOWN benchmark	0: Operating frequency 1: Set frequency	0	★
P0.15	Upper limit frequency offset	0.00 Hz ~ Maximum frequency P0.12	0.00 Hz	☆
P0.16	Lower limit frequency	0.00 Hz ~ Upper limit frequency P0.14	0.00 Hz	☆
P0.17	Carrier frequency	1.0 kHz ~ 16.0 kHz	Model confirmed	☆
P0.18	Carrier frequency adjusts with temperature	0:No 1:Yes	1	☆
P0.19	Acceleration/deceleration time unit	0:1 Second 1: 0.1 Second 2: 0.01 Second	1	★
P0.21	Auxiliary frequency source bias frequency during superposition	0.00 Hz ~ Maximum frequency P0.12	0.00 Hz	☆
P0.22	Frequency command resolution	1: 0.1Hz 2:0.01 Hz	2	★
P0.23	Digital setting frequency shutdown memory	0: No memory 1:Memory	0	☆

	selection			
P0.24	Acceleration/deceleration time reference frequency	0:Maximum frequency ( P0.12 ) 1: Set frequency 2:100 Hz	0	★
P0.25	Runtime frequency instructions UP / DOWN benchmark	0: Operating frequency 1: Set frequency	0	★
P0.26	Command source bundled with frequency source	Units: Control Panel Command Binding Frequency Source Selection 0: Unbound 1: Digital Setpoint Frequency 2: FIV 3: FIC 4: Reserved 5: PULSE Pulse Setting (S3) 6: Multi-Speed 7: Simplified PLC 8: PID 9: Communication Setpoint Tens: Terminal Command Binding Frequency Source Selection Hundreds: Communication Command Binding Frequency Source Selection Thousands: Reserved	0000	☆
P0.27	Communication type	0 Modbus	0	☆

P1 Group Start-stop control				
P1.00	Startup method	0:Direct Start 1:Speed tracking restart 2: Pre-excitation start (AC asynchronous machine)	0	☆
P1.01	Speed tracking method	0: Starting from the downtime frequency 1:Starting from zero speed 2:Starting from the highest frequency	0	★
P1.02	Speed tracking speed	1~100	20	☆
P1.03	Startup frequency	0.00 Hz ~ 10.00 Hz	0.00 Hz	☆
P1.04	Startup frequency retention time	0.0s ~ 100.0s	0.0s	★
P1.05	Starting DC braking current / pre-excitation current	0% ~ 100%	0%	★
P1.06	DC braking time / pre- excitation time	0.0s ~ 100.0s	0.0s	★
P1.07	Acceleration and deceleration methods	0: Linear acceleration and deceleration 1: S Curve acceleration and decelerationA 2:S Curve acceleration and decelerationB	0	★
P1.08	The proportion of the initial period of the S-curve	0.0% ~ ( 100.0% - P1.09 )	30.0%	★
P1.09	The proportion of the time segment ending the S-curve	0.0% ~ ( 100.0% - P1.08 )	30.0%	★
P1.10	Shutdown methods	0: Slow down and stop 1:Free parking	0	☆
P1.11	DC braking start frequency during shutdown	0.00 Hz ~ Maximum frequency	0.00 Hz	☆
P1.12	DC braking waiting time during shutdown	0.0s ~ 100.0s	0.0s	☆
P1.13	DC braking current during shutdown	0% ~ 100%	0%	☆
P1.14	DC braking time during shutdown	0.0s ~ 100.0s	0.0s	☆
P1.15	Brake utilization	0% ~ 100%	100%	☆

<b>P2 Motor parameters</b>				
P2.00	Motor type	0- Ordinary asynchronous motor 1- Variable frequency asynchronous motor	0	★
P2.01	Motor rated power	0.1 kW ~ 450.0 kW	Model confirmed	★
P2.02	Motor rated voltage	1V ~ 2000V	Model confirmed	★
P2.03	Motor rated current	0.01A ~ 655.35A (Inverter power ≤ 55kW )  0.1A ~ 6553.5A (Inverter power > 55 kW )	Model confirmed	★
P2.04	Motor rated frequency	0.01 Hz ~ Maximum frequency	Model confirmed	★
P2.05	Motor rated speed	1 rpm ~ 65535 rpm	Model confirmed	★
P2.06	Asynchronous motor stator resistance	0.001Ω ~ 65.535Ω (Inverter power ≤ 55kW ) 0.0001Ω ~ 6.5535Ω (Inverter power > 55 kW )	Tuning parameters	★
P2.07	Asynchronous motor rotor resistance	0.001Ω ~ 65.535Ω (Inverter power ≤ 55 kW ) 0.0001Ω ~ 6.5535Ω (Inverter power > 55 kW )	Tuning parameters	★
P2.08	Leakage inductance of asynchronous motor	0.01 mH ~ 655.35 mH (Inverter power ≤ 55 kW ) 0.001 mH ~ 65.535 mH (Inverter power > 55 kW )	Tuning parameters	★
P2.09	Asynchronous motor mutual inductance	0.1 mH ~ 6553.5 mH (Inverter power ≤ 55 kW ) 0.01 mH ~ 655.35 mH (Inverter power > 55 kW )	Tuning parameters	★
P2.10	Asynchronous motor no-load current	0.01A ~ P2.03 (Inverter power ≤ 55 kW ) 0.1A ~ P2.03 (Inverter power > 55 kW )	Tuning parameters	★
P2. 11 to P2. 36 are retained.				
P2.37	Tuning selection	0: No operation 1: Asynchronous machine static self-learning 2: Asynchronous machine dynamic self-learning	0	★
<b>P3 Group Motor vector control parameters</b>				
P3.00	Velocity loop proportional gain 1	1 to 100	30	☆
P3.01	Velocity loop	0.01s ~ 10.00s	0.50s	☆

	integral time 1			
P3.02	Switching frequency 1	0.00 ~ P3.05	5.00 Hz	☆
P3.03	Velocity loop proportional gain 2	1 to 100	20	☆
P3.04	Velocity loop integral time 2	0.01s ~ 10.00s	1.00s	☆
P3.05	Switching frequency 2	P3.02 ~ Maximum Frequency	10.00 Hz	☆
P3.06	Vector control slip gain	50% ~ 200%	100%	☆
P3.07	Velocity loop filter time constant	0.000s ~ 0.100s	0.000s	☆
P3.08	Vector control overexcitation gain	0 ~ 200	64	☆
P3.09	Upper limit source under speed control mode	0:Function code P3.10 settings 1:FIV 2:FIC 3:Reserve 4:Pulse setting 5:Communication given 6:MIN ( FIV , FIC ) 7:MAX ( FIV , FIC ) The full-scale range for options 1-7 corresponds to P3.10.	0	☆
P3.10	Torque limit number under speed control mode set up	0.0% ~ 200.0%	150.0%	☆
P3.13	Excitation regulation proportional gain	0 ~ 60000	2000	☆
P3.14	Excitation regulation integral gain	0 ~ 60000	1300	☆
P3.15	Torque regulation proportional gain	0 ~ 60000	2000	☆
P3.16	Torque regulation integral gain	0 ~ 60000	1300	☆
P3.17	Speed ring integral attribute	Units digit: Separation of integrals 0:invalid 1:efficient	0	☆
P3.18	Reserve			
P3.19	Reserve			
P3.20	Reserve			
P3.21	Reserve			
P3.22	Reserve			

P4 Group V/F control parameters				
P4.00	VF Curve setting	0 : Straight lineV/F 1 : MoreV/F 2 : squareV/F 3 : 1.2 PowerV/F 4 : 1.4 PowerV/F 6 : 1.6 PowerV/F 8 : 1.8 PowerV/F 9 : Reserve 10 : VF Completely separated mode 11 : VF Semi-separation mode	0	★
P4.01	Torque boost	0.0% : ( Automatic torque boost) 0.1% ~ 30.0%	Model confirmed	☆
P4.02	Torque boost cutoff frequency	0.00 Hz ~ Maximum frequency	50.00 Hz	★
P4.03	MoreVF Frequency point 1	0.00 Hz ~ P4.05	0.00 Hz	★
P4.04	MoreVF Voltage point 1	0.0% ~ 100.0%	0.0%	★
P4.05	MoreVF Frequency point2	Pages 4.03 to 4.07	0.00 Hz	★
P4.06	MoreVF Voltage point2	0.0% ~ 100.0%	0.0%	★
P4.07	MoreVF Frequency point3	P4.05 ~ Rated frequency of the motor ( P1.04 )	0.00 Hz	★
P4.08	MoreVF Voltage point3	0.0% ~ 100.0%	0.0%	★
P4.09	VF slip compensation gain	0.0% ~ 200.0%	0.0%	☆
P4.10	VF Overexcitation gain	0 ~ 200	64	☆
P4.11	VF Oscillation suppression gain	0 ~ 100	Model confirmed	☆
P4.13	VF Separate voltage sources	0 : Numerical settings ( P4). 14 ) 1 FIV 2 FIC 3 :reserve 4 PULSE Pulse setting ( S3 ) 5 Multi-segment instructions 6 :simplePLC 7 PID 8 Communication given Note: 100.0% corresponds to the rated voltage of the motor.	0	☆
P4.14	VF Separate voltage digital setting	0V ~ Rated voltage of the motor	0V	☆

P4.15	VF Separation voltage rise time	0.0s ~ 1000.0s Note: indicates Time to change from 0V to the motor's rated voltage	0.0s	☆
<b>P5 Group input terminals</b>				
P5.00	FWD Terminal function selection	0 : No function	1	★
P5.01	REV Terminal function selection	1: Forward rotation ( FWD ) 2: Reverse execution ( REV )	4	★
P5.02	S1 Terminal Function Selection	3: Three-wire operation control 4: Forward jog ( FJOG )	9	★
P5.03	S2 terminal function selection	5: Reverse Jog ( RJOG )	12	★
P5.04	S3 Terminal Function Selection	6: TerminalUP 7: Terminal DOWN	13	★
P5.05	S4 Terminal Function Selection	8: Free parking 9: Fault reset ( RESET )	0	★
P5.06	Reserve	10 : Operation paused	0	★
P5.07	Reserve	11 : Normally open input for external faults	0	★
P5.08	Reserve		0	★
P5.09	Reserve	12 : Multi-segment command terminal 1 13 : Multi-segment instruction terminal2 14 : Multi-segment instruction terminal3 15 : Multi-segment instruction terminal4 16 : Acceleration/deceleration time selection terminal 1 17 : Acceleration/deceleration time selection terminal2 18 : Frequency source switching 19 : Up / Down Reset settings (terminals, keyboard) 20 : Run command to switch terminals 21 : Acceleration and deceleration prohibited 22 : PID pause 23 : PLC State Reset 24 : Frequency Pause 25 : Counter Input 26 : Counter Reset 27 : Length Count Input 28 : Length Reset 29 : Torque control disabled 30 : PULSE frequency input (only for ...)S3 efficient)	0	★

		31 : Retain 32 : Immediate DC braking 33 : Normally closed input for external faults 34 : Frequency Modification Enabled 35 : PID Reverse the direction of action 36 : External parking terminal 1 37 : Control command switching terminal2 38 : PID Points paused 39 : Frequency SourceX Switching with preset frequency 40 : Frequency SourceY and preset frequency switching 41 : Retain 42 : Retain 43 : PID Parameter switching 44 : Retain 45 : Retain 46 : Speed control / torque control switching 47 : Emergency Stop 48 : External parking terminal2 49 : Deceleration DC Braking 50 : This run time is reset to 0 51-59: Retained.		
P5.10	Switching quantity filtering time	0.000s ~ 1.000s	0.010s	☆
P5.11	Terminal command method	0:Two-line type 1 1:Two-line type2 2: Three-line 1 3:Three-line2	0	★
P5.12	Terminal UP / DOWN rate of change	0.001 Hz /s ~ 65.535 Hz /s	1.00 Hz /s	☆
P5.13	FI curve 1 Minimum Input	0.00V ~ P5.15	0.00V	☆
P5.14	FI curve 1 Minimum input corresponding settings	-100.0% to +100.0%	0.0%	☆
P5.15	FI curve 1 Maximum Input	P5.13 ~ +10.00V	10.00V	☆
P5.16	FI curve 1 Maximum input corresponding settings	-100.0% to +100.0%	100.0%	☆

P5.17	FI curve 1 Filtering time	0.00s ~ 10.00s	0.10s	☆
P5.18	FI curve2 Minimum Input	0.00V ~ P5.20	0.00V	☆
P5.19	FI curve2 Minimum input corresponding settings	-100.0% to +100.0%	0.0%	☆
P5.20	FI curve2 Maximum Input	P5.18 ~ +10.00V	10.00V	☆
P5.21	FI curve2 Maximum input corresponding settings	-100.0% to +100.0%	100.0%	☆
P5.22	FI curve2 Filtering Time	0.00s ~ 10.00s	0.10s	☆
P5.23	FI curve3 Minimum Input	-10.00V ~ P5.25	0.00V	☆
P5.24	FI curve3 Minimum input corresponding settings	-100.0% to +100.0%	-100.0%	☆
P5.25	FI curve3 Maximum Input	P5.23 ~ +10.00V	10.00V	☆
P5.26	FI curve3 Maximum input corresponding settings	-100.0% to +100.0%	100.0%	☆
P5.27	FI curve3 Filtering time	0.00s ~ 10.00s	0.10s	☆
P5.28	PULSE Minimum Input	0.00 kHz ~ P5.30	0.00 kHz	☆
P5.29	PULSE Minimum input corresponding settings	-100.0% ~ 100.0%	0.0%	☆
P5.30	PULSE Maximum Input	P5.28 ~ 100.00 kHz	50.00 kHz	☆
P5.31	PULSE Maximum input corresponding settings	-100.0% ~ 100.0%	100.0%	☆
P5.32	PULSE Filtering time	0.00s ~ 10.00s	0.10s	☆
P5.33	FI Curve selection	Units: FIV Curve Selection 1: Curve 1 (2 points, see P5.13–P5.16) 2: Curve 2 (2 points, see P5.18–P5.21) 3: Curve 3 (2 points, see P5.23–P5.26) 4: Curve 4 (4 points, see C6.00–C6.07) 5: Curve 5 (4 points, see C6.08–C6.15) Tens: FIC curve selection, same as above Hundreds: Reserved	321	☆

P5.34	FI Select below minimum input setting	Units : FIV Select below minimum input setting 0: Corresponds to the minimum input setting 1:0.0% Tens: FIC Select below the minimum input setting , same as above. Hundreds: Reserved	000	☆
P5.35	FWD Delay time	0.0s ~ 3600.0s	0.0s	★
P5.36	REV Delay time	0.0s ~ 3600.0s	0.0s	★
P5.37	S1 Delay time	0.0s ~ 3600.0s	0.0s	★
P5.38	S- Terminal Effective Mode Selection 1	0: High level is active 1 : Active low Units digit: FWD Tens: REV Hundreds: S1 Thousands: S2 Ten thousandths place: S3	00000	★
P5.39	S- Terminal Effective Mode Selection2	0: High level is active 1 : Low-level active unit: S4 Tens: Reserved Hundreds: Reserved Thousands: Reserved Ten thousandths place: reserved	00000	★

P6 Group output terminals				
P6.00	MO 1 Terminal output mode selection	1: Switch output ( MO 1 )	1	☆
P6.01	MO 1 Output Function Selection	0: No output	0	☆
P6.02	Control board relay function selection ( RA - RB - RC )	1: Inverter in operation	2	☆
		2: Fault output (fault shutdown)		
		3: Frequency level detection FDT 1 output		
		4: Frequency reached		
		5: Zero-speed operation (no output when stopped)		
P6.03	Reserve			☆
P6.04	Reserve			☆
P6.05	Reserve	6: Motor overload warning		☆
		7: Inverter overload warning		
		8 : The set value has been reached		
		9 : The specified value has been reached		
		10 : Length reached		
		11 : PLC Loop complete		
		12 : Cumulative running time reached		
		13 : Frequency limited		
		14 : Torque Limiting		
		15 : Ready to run		
		16 : FIV > FIC		
		17 : Upper limit frequency reached		
		18 : Lower limit frequency reached (operation-related)		
		19 : Undervoltage output		
		20 : Communication Settings		
		21 : Location complete (keep)		
		22 : Location close (reserved)		
		23 : Zero-speed operation 2 (output also when stopped)		
		24 : Cumulative power-on time reached		
		25 : Frequency Level Detection FDT 2 output		
		26 : Frequency 1 Arrival Output		
		27 : Frequency2 Arrival Output		
		28 :Current 1 Arrival Output		
		29 :Current2 Arrival Output		
		30 : Timed arrival output		
		31 : FIV Input limit exceeded		
		32 : Loading		
		33 : Running in reverse		
		34 : Zero current state		
		35 : Module temperature reached		

		36 : Output current exceeds limit 37 : Lower limit frequency reached (output even when the machine is stopped) 38 : Alarm output (continue running) 39 : Retain 40 : This run has ended.		
P6.06	Reserve	0: Operating frequency 1 : Set frequency 2 :Output current 3 :Output torque 4 :Output power 5: Output voltage 6 :PULSE enter ( 100.% correspondence) 100.0	0	☆
P6.07	FOV Output function selection	kHz 7 :FIV 8 :FIC 9:Reserve 10 : Length 11 : Count value 12 : Communication Settings 13 :Mtor speed 14 : Output electricity flow( 100.0%) right( 1000.0A ) 15 : Output electricity Pressure( 100.0%) right(Should be 1000.0V ) 16 : Reserve	0	☆
P6.08	FOC Output function selection (optional)		1	☆
P6.09	Reserve			☆
P6.10	FOV Zero bias coefficient	-100.0% to +100.0%	0.0%	☆
P6.11	FOV Gain	-10.00 to +10.00	1.00	☆
P6.12	FOC Zero bias coefficient	-100.0% to +100.0%	0.0%	☆
P6.13	FOC Gain	-10.00 to +10.00	1.00	☆
P6.17	MO 1 output delay time	0.0s ~ 3600.0s	0.0s	☆
P6.18	RA - RB - RC lose Output delay time	0.0s ~ 3600.0s	0.0s	☆
P6.19	Reserve			☆
P6.20	Reserve			☆

P6.21	Reserve			☆
P6.22	Output terminal valid state selection	0:Positive logic 1:Anti-logic Units digit: MO 1 Tens: RA - RB - RC Hundreds: Reserved Thousands: Reserved Ten thousandths place: reserved	00000	☆
<b>P7 Group Keyboard and Display</b>				
P7.00	Output power correction factor	0.0~200.0	100.0	☆
P7.01	JOG Function selection	0:This key has no function. 1 : Switch between keyboard commands and remote operation. This refers to switching the command source, specifically switching between the current command source and keyboard control (local operation). If the current command source is keyboard control, this key function will be ineffective. 2: Forward/reverse switching is successful.JOG The key toggles the direction of frequency commands. This function is only available when the command source is the operation panel command channel. 3:Forward jog via keyboard JOG The key enables forward jogging ( JOG - FWD ). 4: Reverse jog via keyboard JOG The key enables reverse jogging ( JOG - REV ). 5: A 6-key keyboard with a valid stop key.	0	★
P7.02	STOP / RESET Key Function	0 : Only exist key plate Hold do Way Down STOP / RESET Key-based stop function is effective 1 : exist appoint what Hold do square Mode Down STOP / RESET The key-operated stop function is effective.	1	☆

P7.03	Led Run display parameters 1	0000 ~ FFFF Bit 00: Operating frequency 1 ( Hz ) Bit 01: Set frequency ( Hz ) Bit 02: Bus voltage ( V ) Bit 03: Output Voltage ( V ) Bit 04: Output Current ( A ) Bit 05: Output power ( kW ) Bit 06: Output torque ( % ) Bit 07: S Input Status Bit 08: MO 1 output status Bit 09: FIV Voltage ( V ) Bit 10: FIC Voltage ( V ) Bit 11: reserve Bit 12: Count value Bit 13: Length value Bit 14: Load speed display Bit 15: PID setting	1F	☆
P7.04	Led Run display parameters 2	0000~FFFF Bit00: PID Feedback Bit01: PLC Stage Bit02: PULSE Input Pulse Frequency (kHz) Bit03: Operating Frequency 2 (Hz) Bit04: Remaining Run Time Bit05: FIV Pre-Calibration Voltage (V) Bit06: FIC Pre-Calibration Voltage (V) Bit07: Reserved Bit08: Linear Speed Bit09: Current Power-On Time (Hour) Bit10: Current Running Time (Min) Bit11: PULSE Input Pulse Frequency (Hz) Bit12: Communication Setpoint Bit13: Reserved Bit14: Main Frequency X Display (Hz) Bit15: Auxiliary Frequency Y Display (Hz)	0	☆

P7.05	Led Stop display parameters	0000~FFFF Bit00: Set frequency (Hz) Bit01: Bus voltage (V) Bit02: X input status Bit03: YO output status Bit04: FIV voltage (V) Bit05: FIC voltage (V) Bit06: FIA voltage (V) Bit07: Count value Bit08: Length value Bit09: PLC stage Bit10: Load speed Bit11: PID setpoint Bit12: PULSE input pulse frequency (kHz) Bit13: PID feedback value	33	☆
P7.06	Load speed display coefficient	0.0001 ~ 6.5000	1.0000	☆
P7.07	Inverter module heat sink temperature	0.0 °C ~ 100.0 °C	-	●
P7.08	Rectifier bridge heat sink temperature	0.0 °C ~ 100.0 °C	-	●
P7.09	Cumulative running time	0h ~ 65535h	-	●
P7.10	Reserve	-	-	●
P7.11	Software version	-	-	●
P7.12	Load speed display decimal places	0: 0 Decimal places 1: 1 Decimal places 2: 2 Decimal places 3: 3 Decimal places	1	☆
P7.13	Total power-on time	0h ~ 65535h	-	●
P7.14	Cumulative electricity consumption	0 kWh to 65,535 kWh	-	●

P8 Group Accessibility				
P8.00	Jog operation frequency	0.00 Hz ~ Maximum frequency	2.00 Hz	☆
P8.01	Inching acceleration time	0.0s ~ 6500.0s	20.0s	☆
P8.02	Inching deceleration time	0.0s ~ 6500.0s	20.0s	☆
P8.03	Acceleration time 2	0.0s ~ 6500.0s	Model confirmed	☆
P8.04	Deceleration time 2	0.0s ~ 6500.0s	Model confirmed	☆
P8.05	Acceleration time 3	0.0s ~ 6500.0s	Model confirmed	☆
P8.06	Deceleration time 3	0.0s ~ 6500.0s	Model confirmed	☆
P8.07	Acceleration time 4	0.0s ~ 6500.0s	Model confirmed	☆
P8.08	Deceleration time 4	0.0s ~ 6500.0s	Model confirmed	☆
P8.09	Jump frequency 1	0.00 Hz ~ Maximum frequency	0.00 Hz	☆
P8.10	Jump frequency 2	0.00 Hz ~ Maximum frequency	0.00 Hz	☆
P8.11	Jump frequency amplitude	0.00 Hz ~ Maximum frequency	0.00 Hz	☆
P8.12	Forward and reverse dead zone time	0.0s ~ 3000.0s	0.0s	☆
P8.13	Invert control enable	0:allow 1:prohibit	0	☆
P8.14	Set frequency below the lower limit frequency Operating mode	0:Operating at the following frequency limit 1:Shutdown 2:Zero-speed operation	0	☆
P8.15	Sagging control	0.00 Hz ~ 10.00 Hz	0.00 Hz	☆
P8.16	Set cumulative power-on arrival time	0h ~ 65000h	0h	☆
P8.17	Set cumulative running time	0h ~ 65000h	0h	☆
P8.18	Start Protection Selection	0 No protection 1:Protect	0	☆
P8.19	Frequency detection value ( FDT 1 )	0.00 Hz ~ Maximum frequency	50.00 Hz	☆
P8.20	Frequency detection stagnation back Value ( FDT 1 )	0.0% ~ 100.0% ( FDT 1 ) (Level)	5.0%	☆
P8.21	Frequency reaches	0.0% ~ 100.0% (maximum	0.0%	☆

	detection width	frequency)		
P8.22	Frequency of jumps during acceleration and deceleration Is it effective?	0:invalid 1:efficient	0	☆
P8.25	Acceleration time 1 With acceleration time2. Frequency switching point	0.00 Hz ~ Maximum frequency	0.00 Hz	☆
P8.26	Deceleration time 1 With deceleration time2. Frequency switching point	0.00 Hz ~ Maximum frequency	0.00 Hz	☆
P8.27	Terminal inching priority	0:invalid 1:efficient	0	☆
P8.28	Frequency detection value ( FDT 2 )	0.00 Hz ~ Maximum frequency	50.00 Hz	☆
P8.29	Frequency detection stagnation back Value ( FDT 2 )	0.0% to 100.0% (FDT2 Level)	5.0%	☆
P8.30	Arbitrary arrival frequency detection value 1	0.00 Hz ~ Maximum frequency	50.00 Hz	☆
P8.31	Arbitrary arrival frequency detection bandwidth 1	0.0% ~ 100.0% (maximum frequency)	0.0%	☆
P8.32	Arbitrary arrival frequency detection value 2	0.00 Hz ~ Maximum frequency	50.00 Hz	☆
P8.33	Arbitrary arrival frequency detection bandwidth2	0.0% ~ 100.0% (maximum frequency)	0.0%	☆
P8.34	Zero current detection level	0.0% ~ 300.0% 100.0% corresponds to the motor's rated current	5.0%	☆
P8.35	Zero current detection delay time	0.01s ~ 600.00s	0.10s	☆
P8.36	Output current exceeds limit	0.0% (Not tested) 0.1% ~ 300.0% (Motor rated current)	200.0%	☆
P8.37	Output current over-limit detection delay time	0.00s ~ 600.00s	0.00s	☆
P8.38	Arbitrary arrival current 1	0.0% ~ 300.0% (Motor rated current)	100.0%	☆

P8.39	Arbitrary arrival current 1 width	0.0% ~ 300.0% (Motor rated current)	0.0%	☆
P8.40	Arbitrary arrival current2	0.0% ~ 300.0% (Motor rated current)	100.0%	☆
P8.41	Arbitrary arrival current2 width	0.0% ~ 300.0% (Motor rated current)	0.0%	☆
P8.42	Timer function selection	0: Invalid 1: Effective	0	☆
P8.43	Scheduled run time selection	0 P8.44 set up 1 FIV 2 FIC 3:reserve Analog input range correspondence P8.44	0	☆
P8.44	Scheduled run time	0.0 Min ~ 6500.0 Min	0.0 Min	☆
P8.45	FIV Lower limit of input voltage protection value	0.00V ~ P8.46	3.10V	☆
P8.46	FIV Upper limit of input voltage protection value	P8.45 ~ 10.00V	6.80V	☆
P8.47	Module temperature reached	0 °C~ 100 °C	75 °C	☆
P8.48	Cooling fan control	0 The fan operates during operation. 1 The fan keeps running.	0	☆
P8.49	Wake-up frequency	Sleep frequency ( P8.51 ) ~ Maximum frequency ( P0.12 )	0.00 Hz	☆
P8.50	Wake-up delay	0.0s ~ 6500.0s	0.0s	☆
P8.51	Sleep frequency	0.00 Hz ~ Wake-up frequency ( P8.49 )	0.00 Hz	☆
P8.52	Hibernation delay time	0.0s ~ 6500.0s	0.0s	☆
P8.53	Arrival time setting for this run	0.0 Min ~ 6500.0 Min	0.0 Min	☆
<b>P9 Group Fault and Protection</b>				
P9.00	Motor overload protection selection	0:prohibit 1:allow	1	☆
P9.01	Motor overload protection gain	0.20 ~ 10.00	1.00	☆
P9.02	Motor overload warning coefficient	50% ~ 100%	80%	☆
P9.03	Overvoltage stall gain	0 ~ 100	0	☆
P9.04	Overvoltage stall protection voltage	120% ~ 150%	130%	☆
P9.05	Throughflow velocity gain	0 ~ 100	20	☆
P9.06	Overcurrent protection current	100% ~ 200%	150%	☆

P9.07	Power-on short-circuit protection selection	0:invalid 1:efficient	1	☆
P9.09	Number of automatic fault resets	0 ~ 20	0	☆
P9.10	Fault during automatic reset MO 1 Action selection	0 No action 1:action	0	☆
P9.11	Automatic fault reset interval	0. 1s ~ 100.0s	1.0s	☆
P9.12	Reserve			☆
P9.13	Output phase loss protection selection	0:prohibit 1:allow	1	☆
P9.14	First type of failure	0:No faults 1 :Inverter unit protection 2 : Accelerate over-current 3 :Deceleration over-current 4: Constant speed over-current 5 :Accelerating overvoltage 6: Deceleration over-voltage 7 :Constant-rate overvoltage 8 : Buffer resistor overload 9: Under-voltage 10 : Inverter overload 11 :Motor overload 12 : Retain	-	●
P9.15	Second type of failure	13 : Output phase loss 14 : Module overheating 15 : External Faults 16 : Communication error 17 : Contactor malfunction 18 :Current detection abnormality 19 :Motor self-learning anomaly 20 : Retain 21 : Parameter read/write error 22 : Inverter hardware malfunction twenty three :Motor short circuit to ground 24 : Retain 25 : Retain	-	●

P9.16	Third (most recent) fault type	26 : Running time reached 27: reserve 28: reserve 29: Power-on time has arrived 30 : Loadout 31 : RuntimePID Feedback lost 40 : Fast rate limiting timeout 41 : Reserved 42: Reserved 43 : Reserved 45 : Reserved 51 : Reserved	-	•
P9.17	The third (most recent) fault	-	-	•
P9.18	The third (most recent) fault	-	-	•
P9.19	Bus voltage during the third (most recent) fault	-	-	•
P9.20	Input terminal status during the third (most recent) fault	-	-	•
P9.21	Output terminal status during the third (most recent) fault	-	-	•
P9.22	Inverter status during the third (most recent) fault	-	-	•
P9.23	Power-on time during the third (most recent) fault	-	-	•
P9.24	Runtime during the third (most recent) failure	-	-	•
P9.27	Frequency during the second fault	-	-	•
P9.28	Current during the second fault	-	-	•
P9.29	Bus voltage during the second fault	-	-	•

P9.30	Input terminal status during the second fault	-	-	•
P9.31	Output terminal status during the second fault	-	-	•
P9.32	Status during the second fault	-	-	•
P9.33	Power-on time during the second fault	-	-	•
P9.34	Runtime during the second failure	-	-	•
P9.37	Frequency at the first fault	-	-	•
P9.38	Current during the first fault	-	-	•
P9.39	Bus voltage during the first fault	-	-	•
P9.40	Input terminal status during the first fault	-	-	•
P9.41	Output terminal status during the first fault	-	-	•
P9.42	Status during the first fault	-	-	•
P9.43	Power-on time during the first fault	-	-	•
P9.44	Runtime during the first failure	-	-	•
P9.47	Fault protection action selection 1	Units: Motor overload (OL1) 0: Free stop 1: Stop according to stop mode 2: Continue operation Tens: Reserved Hundreds: Output phase loss (LO) Thousands: External fault (EF) Ten thousands: Communication error (CE)	00000	☆

P9.48	Fault protection action selection2	Units: Reserved 0: Free parking Tens: Function code read/write error (EEP) 0: Free parking 1: Shutdown via stop mode Hundreds: Reserved Thousands: Reserved Ten thousands: Operating time reached (END1)	00000	☆
P9.49	Fault protection action selection3	Units: Reserved 0: Free coast to stop 1: Stop according to stop mode 2: Continue operation Tens: Reserved 0: Free coast to stop 1: Stop according to stop mode 2: Continue operation Hundreds: Power-up time reached (END2) 0: Free coast to stop 1: Stop according to stop mode 2: Continue operation Thousands place: Load shedding (LOAD) 0: Free stop 1: Decelerate to stop 2: Decelerate to 7% of motor rated frequency and continue operation; automatically resume at set frequency when load is restored Ten thousands place: PID feedback loss during operation (PIDE) 0: Free stop 1: Stop according to stop mode 2: Continue running	00000	☆
P9.50	Reserve			☆
P9.54	Selection for continued operation during failure	0:Run at the current operating frequency 1:Run at the set frequency 2:Run at the maximum frequency 3:The following frequency limits are applied. 4: Operating at abnormal standby frequency	0	☆

P9.55	Abnormal standby frequency	60.0%–100.0% (100.0% corresponds to maximum frequency P0.12)	100.0%	☆
P9.59	Instantaneous power outage action selection	0 :invalid 1 :slow down 2 :Deceleration and Stop	0	☆
P9.60	Instantaneous power outage pauses voltage judgment	P9.62 ~ 100.0%	90.0%	☆
P9.61	Instantaneous and continuous voltage rebound judgment time	0.00s ~ 100.00s	0.50s	☆
P9.62	Instantaneous and continuous action to determine voltage	60.0% ~ 100.0% (Standard bus voltage)	80.0%	☆
P9.63	Load drop protection selection	0 :invalid 1 :efficient	0	☆
P9.64	Load drop detection level	0.0 ~ 100.0 %	10.0%	☆
P9.65	Load drop detection time	0.0 ~ 60.0s	1.0s	☆
P9.67	Reserve			☆
P9.68	Reserve			☆
P9.69	Reserve			☆
P9.70	Reserve			☆
<b>PA Group PID Function</b>				
PA .00	PID Given source	0: PA.01 Setting 1: FIV 2: FIC 3: Reserved 4: PULSE Pulse Setting (S3) 5: Communication Command 6: Multi-Step Command	0	☆
PA .01	PID Given a numerical value	0.0% ~ 100.0%	50.0%	☆
PA .02	PID Feedback source	0: FIV 1: FIC 2: Hold 3: FIV-FIC 4: PULSE pulse setting (S3) 5: Communication setpoint 6: FIV+FIC 7: MAX( FIV ,  FIC ) 8: MIN( FIV ,  FIC )	0	☆

PA .03	PID Direction of action	0 : Positive effect 1 :reaction	0	☆
PA .04	PID Given feedback range	0 ~ 65535	1000	☆
PA .05	Proportional gainKp 1	0.0 ~ 100.0	20.0	☆
PA .06	Points TimeTi 1	0.01s ~ 10.00s	2.00s	☆
PA .07	Differential timeTd 1	0.000s ~ 10.000s	0.000s	☆
PA .08	PID Reverse cutoff frequency	0.00 ~ Maximum frequency	2.00 Hz	☆
PA .09	PID Deviation Limit	0.0% ~ 100.0%	0.0%	☆
PA .10	PID Differential limiting	0.00% ~ 100.00%	0.10%	☆
PA .11	PID Given change time	0.00 ~ 650.00s	0.00s	☆
PA .12	PID Feedback filtering time	0.00 ~ 60.00s	0.00s	☆
PA .13	PID Output filtering time	0.00 ~ 60.00s	0.00s	☆
PA .14	Reserve	-	-	☆
PA .15	Proportional gainKp 2	0.0 ~ 100.0	20.0	☆
PA .16	Points TimeTi 2	0.01s ~ 10.00s	2.00s	☆
PA .17	Differential timeTd 2	0.000s ~ 10.000s	0.000s	☆
PA .18	PID Parameter switching conditions	0 Do not switch 1 :pass S Terminal switching 2 Automatic switching based on deviation	0	☆
PA .19	PID Parameter switching deviation 1	0.0% ~ PA .20	20.0%	☆
PA .20	PID Parameter switching deviation 2	PA .19 ~ 100.0%	80.0%	☆
PA .21	PID initial value	0.0% ~ 100.0%	0.0%	☆
PA .22	PID Initial value retention time	0.00 ~ 650.00s	0.00s	☆
PA .23	Maximum positive deviation between two outputs	0.00% ~ 100.00%	1.00%	☆
PA .24	The maximum value of the opposite deviation between the two outputs	0.00% ~ 100.00%	1.00%	☆

PA .25	PID Points attributes	Units digit: Separation of integrals 0 :invalid 1 :efficient Tens digit: Whether to stop integrating after the output reaches the limit. 0 Continue accumulating points 1 Stop integrating	00	☆
PA .26	PID Feedback on missing detection value	0.0%: No determination of feedback loss 0.1%–100.0%	0.0%	☆
PA .27	PID Feedback on lost detection time	0.0s ~ 20.0s	0.0s	☆
PA .28	PID halting operation	0 Stop the machine and do not perform calculations. 1 Operations during shutdown	0	☆
<b>Pb Pendulum frequency, fixed length and counting</b>				
Pb .00	Swing frequency setting method	0: No operation during shutdown 1: Operation during shutdown	0	☆
Pb .01	Swing frequency amplitude	0.0% ~ 100.0%	0.0%	☆
Pb .02	Jump frequency amplitude	0.0% ~ 50.0%	0.0%	☆
Pb .03	Swing frequency period	0.1s ~ 3000.0s	10.0s	☆
Pb .04	Rise time of the triangular wave of the oscillation frequency	0.1% ~ 100.0%	50.0%	☆
Pb .05	Set length	0m ~ 65535m	1000m	☆
Pb .06	Actual length	0m ~ 65535m	0m	☆
Pb .07	Pulses per meter	0.1 ~ 6553.5	100.0	☆
Pb .08	Set count value	1 ~ 65535	1000	☆
Pb .09	Specify count value	1 ~ 65535	1000	☆
<b>PC Group Multi-segment instructions, simplified PLC</b>				
PC .00	Multi-segment instructions0	-100.0% ~ 100.0%	0.0%	☆

PC .01	Multi-segment instructions 1	-100.0% ~ 100.0%	0.0%	☆
PC .02	Multi-segment instructions 2	-100.0% ~ 100.0%	0.0%	☆
PC .03	Multi-segment instructions 3	-100.0% ~ 100.0%	0.0%	☆
PC .04	Multi-segment instructions 4	-100.0% ~ 100.0%	0.0%	☆
PC .05	Multi-segment instructions 5	-100.0% ~ 100.0%	0.0%	☆
PC .06	Multi-segment instructions 6	-100.0% ~ 100.0%	0.0%	☆
PC .07	Multi-segment instructions 7	-100.0% ~ 100.0%	0.0%	☆
PC .08	Multi-segment instructions 8	-100.0% ~ 100.0%	0.0%	☆
PC .09	Multi-segment instructions 9	-100.0% ~ 100.0%	0.0%	☆
PC .10	Multi-segment instructions 10	-100.0% ~ 100.0%	0.0%	☆
PC .11	Multi-segment instructions 11	-100.0% ~ 100.0%	0.0%	☆
PC .12	Multi-segment instructions 12	-100.0% ~ 100.0%	0.0%	☆
PC .13	Multi-segment instructions 13	-100.0% ~ 100.0%	0.0%	☆
PC .14	Multi-segment instructions 14	-100.0% ~ 100.0%	0.0%	☆
PC .15	Multi-segment instructions 15	-100.0% ~ 100.0%	0.0%	☆
PC .16	Simple PLC Operating mode	0 Shutdown after a single run 1 Retain final value after a single run 2: Keep looping	0	☆
PC .17	Simple PLC Power-off memory selection	Units: Power-off memory selection 0: Does not remember when power is off 1 Power-off memory Tens: Stop memory selection 0 Shutdown does not remember 1 Shutdown memory	00	☆

PC .18	Simple PLC No.0-segment running time	0.0s ( h ) ~ 6553.5s ( h )	0.0s ( h )	☆
PC .19	Simple PLC No.0-stage acceleration/deceleration time selection	0 ~ 3	0	☆
PC .20	Simple PLC No. 1 running time	0.0s ( h ) ~ 6553.5s ( h )	0.0s ( h )	☆
PC .21	Simple PLC No. 1-stage addition and subtraction Speed Time Selection	0 ~ 3	0	☆
PC .22	Simple PLC 2nd Segment running time	0.0s ( h ) ~ 6553.5s ( h )	0.0s ( h )	☆
PC .23	Simple PLC 2nd Segment acceleration /deceleration time selection	0 ~ 3	0	☆
PC .24	Simple PLC No.3 running times	0.0s ( h ) ~ 6553.5s ( h )	0.0s ( h )	☆
PC .25	Simple PLC No.3-stage acceleration/deceleration time selection	0 ~ 3	0	☆
PC .26	Simple PLC No.4 running times	0.0s ( h ) ~ 6553.5s ( h )	0.0s ( h )	☆
PC .27	Simple PLC No.4-stage acceleration/deceleration time selection	0 ~ 3	0	☆
PC .28	Simple PLC No.5 running times	0.0s ( h ) ~ 6553.5s ( h )	0.0s ( h )	☆
PC .29	Simple PLC No.5-stage acceleration/deceleration time selection	0 ~ 3	0	☆
PC .30	Simple PLC No.6 running times	0.0s ( h ) ~ 6553.5s ( h )	0.0s ( h )	☆
PC .31	Simple PLC No.6-stage acceleration/deceleration time selection	0 ~ 3	0	☆
PC .32	Simple PLC No.7 running times	0.0s ( h ) ~ 6553.5s ( h )	0.0s ( h )	☆
PC .33	Simple PLC No.7-stage acceleration/deceleration time selection	0 ~ 3	0	☆

PC .34	Simple PLC No.8 running times	0.0s ( h ) ~ 6553.5s ( h )	0.0s ( h )	☆
PC .35	Simple PLC No.8-stage acceleration/ deceleration time selection	0 ~ 3	0	☆
PC .36	Simple PLC No.9 running times	0.0s ( h ) ~ 6553.5s ( h )	0.0s ( h )	☆
PC .37	Simple PLC No.9-stage acceleration/ deceleration time selection	0 ~ 3	0	☆
PC .38	Simple PLC No.10 running times	0.0s ( h ) ~ 6553.5s ( h )	0.0s ( h )	☆
PC .39	Simple PLC No.10-stage acceleration/ deceleration time selection	0 ~ 3	0	☆
PC .40	Simple PLC No.11 running times	0.0s ( h ) ~ 6553.5s ( h )	0.0s ( h )	☆
PC .41	Simple PLC No.11-stage acceleration/ deceleration time selection	0 ~ 3	0	☆
PC .42	Simple PLC No.12 running times	0.0s ( h ) ~ 6553.5s ( h )	0.0s ( h )	☆
PC .43	Simple PLC No.12 acceleration/ deceleration time segments choose	0 ~ 3	0	☆
PC .44	Simple PLC No.13 running times	0.0s ( h ) ~ 6553.5s ( h )	0.0s ( h )	☆
PC .45	Simple PLC No.13-stage acceleration/ deceleration time selection	0 ~ 3	0	☆
PC .46	Simple PLC No.14 running times	0.0s ( h ) ~ 6553.5s ( h )	0.0s ( h )	☆
PC .47	Simple PLC No.14-stage acceleration/ deceleration time selection	0 ~ 3	0	☆
PC .48	Simple PLC No.15 running times	0.0s ( h ) ~ 6553.5s ( h )	0.0s ( h )	☆
PC .49	Simple PLC No.15-stage acceleration/ deceleration time selection	0 ~ 3	0	☆

PC .50	Simple PLC Running time unit	0: s (seconds) 1 h (hours )	0	☆
PC .51	Multi-segment instructions0 given method	0 Function codePC .00 given 1 FIV 2 FIC 3:reserve 4 PULSE pulse 5 PID 6 :Preset frequencyRate(P0.10 )GiveCertainly, UP / DOWN Editable	0	☆
Pd Group communication parameters				
PD .00	Baud rate	Units: MODBUS 0:300 BPS 1: 600 BPS 2:1200 BPS 3:2400 BPS 4: 4800 BPS 5:9600 BPS 6 :19200 BPS 7 :38400 BPS 8:57600 BPS 9:115200 BPS Tens of digits:reserved) Hundreds: Retain Thousands: Retain	0005	☆
PD .01	Data format	0:No checksum ( 8-N-2 ) 1 :Even parity ( 8-E-1 ) 2 :Odd parity ( 8-O-1 ) 3: 8-N-1	3	☆
PD .02	Local address	1 to 247 , 0 For broadcast address	1	☆
PD .03	Response delay	0 ms ~ 20 ms	2	☆
PD .04	Communication timeout	0.0 (Invalid ) , 0.1s ~ 60.0s	0.0	☆
PD .05	Data transmission format selection	Units: MODBUS 0: Non-standard MODBUS protocol 1: Standard MODBUS protocol Tens: Reserved	1	☆

PD .06	Communication reading current resolution	0: 0.01A 1: 0.1A	1	☆
<b>PP Group User Function Code</b>				
PP .00	User password	0 ~ 65535	0	☆
PP .01	Parameter initialization	000 : No operation 001 : Restore factory settings, excluding motor parameters .	0	★
<b>C0 Group Torque control parameters</b>				
C0.00	Speed / torque control mode selection	0:Speed control 1:Torque control	0	★
C0.01	Setting source selection under torque control mode	0: Digital setting (C0.03) 1: FIV 2: FIC 3: Reserved 4: PULSE 5: Communication setpoint 6: MIN(FIV,FIC) 7: MAX(FIV,FIC) (Full-scale range for options 1-7, corresponding to digital setting C0.03)	0	★
C0.03	digital setting under torque control mode	-200.0% ~ 200.0%	150.0%	☆
C0.05	Torque control positive maximum frequency	0.00 Hz ~ Maximum frequency	50.00 Hz	☆
C0.06	Torque control reverse maximum frequency	0.00 Hz ~ Maximum frequency	50.00 Hz	☆
C0.07	Torque control acceleration time	0.00s ~ 650.00s	0.00s	☆
C0.08	Torque control deceleration time	0.00s ~ 650.00s	0.00s	☆
<b>C5 Group Control optimization parameters</b>				
C5.00	DPWM Switch upper limit frequency	0.00 Hz ~ 15.00 Hz	12.00 Hz	☆
C5.01	PWM Modulation method	0 Asynchronous modulation 1 Synchronous modulation	0	☆
C5.02	Dead zone compensation mode selection	0 No compensation 1 Compensation Mode 1 2 Compensation Mode2	1	☆
C5.03	RandomPWM depth	0:randomPWM invalid 1-10 : PWM Carrier random depth	0	☆
C5.04	Fast current limiting	0: Do not enable	1	☆

	enable			
		1: Enable		
C5.05	Current sensing compensation	0 ~ 100	5	☆
C5.06	Undervoltage point setting	60.0% ~ 140.0%	90.0%	☆
C5.07	NonePG Optimization mode selection	0: No optimization 1: Optimization mode 1 2: Optimization mode 2	1	☆
<b>C6 Group FIV / FIC Curve setting</b>				
C6.00	FI curve 4 Minimum Input	0.00V ~ C6.02	0.00V	☆
C6.01	FI curve4 Minimum input corresponding settings	-100.0% to +100.0%	0.0%	☆
C6.02	FI curve4 inflection point 1 input	C6.00 ~ C6.04	3.00V	☆
C6.03	FI curve4 Inflection Point 1 Input the corresponding settings	-100.0% to +100.0%	30.0%	☆
C6.04	FI curve4 Inflection Point 2 enter	C6.02 ~ C6.06	6.00V	☆
C6.05	FI curve4 inflection point2 Input the corresponding settings	-100.0% to +100.0%	60.0%	☆
C6.06	FI curve4 Maximum Input	C6.06 ~ +10.00V	10.00V	☆
C6.07	FI curve4 Maximum input corresponding settings	-100.0% to +100.0%	100.0%	☆
C6.08	FI curve5 Minimum Input	0.00V ~ C6.10	0.00V	☆
C6.09	FI curve 5 Minimum input corresponding settings	-100.0% to +100.0%	-100.0%	☆
C6.10	FI curve5 inflection point 1 input	C6.08 ~ C6.12	3.00V	☆
C6.11	FI curve5 Inflection Point 1 Input the corresponding settings	-100.0% to +100.0%	-30.0%	☆
C6.12	FI curve5 Inflection Point 2 enter	C6.10 ~ C6.14	3.00V	☆
C6.13	FI curve5 inflection point2 Input the corresponding settings	-100.0% to +100.0%	30.0%	☆
C6.14	FI curve5 Maximum Input	C6.12 ~ +10.00V	10.00V	☆

C6.15	FI curve5 Maximum input corresponding settings	-100.0% to +100.0%	100.0%	☆
C6.16	FIV Set jump point	-100.0% ~ 100.0%	0.0%	☆
C6.17	FIV Set jump range	0.0% ~ 100.0%	0.5%	☆
C6.18	FIC Set jump point	-100.0% ~ 100.0%	0.0%	☆
C6.19	FIC Set jump range	0.0% ~ 100.0%	0.5%	☆
<b>C9 Group PID Added features</b>				
C9.00	Sleep frequency	0~P0.12	0.00 Hz	☆
C9.01	Hibernation duration	0~5000.0S	10.0S	☆
C9.02	Wake-up value	0~ 100.0%	60.0%	☆
<b>CC Group FIFO Correction</b>				
CC .00	FIV Measured voltage 1	0.500V ~ 4.000V	Factory calibration	☆
CC .01	FIV Display voltage 1	0.500V ~ 4.000V	Factory calibration	☆
CC .02	FIV Measured voltage2	6.000V ~ 9.999V	Factory calibration	☆
CC .03	FIV Display voltage2	6.000V ~ 9.999V	Factory calibration	☆
CC .04	FIC Measured voltage 1	0.500V ~ 4.000V	Factory calibration	☆
CC .05	FIC Display voltage 1	0.500V ~ 4.000V	Factory calibration	☆
CC .06	FIC Measured voltage2	6.000V ~ 9.999V	Factory calibration	☆
CC .07	FIC Display voltage2	6.000V ~ 9.999V	Factory calibration	☆
CC .08	Reserve			☆
CC .09	Reserve			☆
CC .10	Reserve			☆
CC .11	Reserve			☆
CC .12	FOV Target voltage 1	0.500V ~ 4.000V	Factory calibration	☆
CC .13	FOV Measured voltage 1	0.500V ~ 4.000V	Factory calibration	☆
CC .14	FOV Target voltage2	6.000V ~ 9.999V	Factory calibration	☆
CC .15	FOV Measured voltage2	6.000V ~ 9.999V	Factory calibration	☆

CC .16	FOC target voltage 1	0.500V ~ 4.000V	Factory calibration	☆
CC .17	FOC Measured voltage 1	0.500V ~ 4.000V	Factory calibration	☆
CC .18	FOC target voltage2	6.000V ~ 9.999V	Factory calibration	☆
CC .19	FOC Measured voltage2	6.000V ~ 9.999V	Factory calibration	☆

### Summary of monitoring parameters:

Function code	Name	Smallest unit
<b>D0 Group Basic monitoring parameters</b>		
D0.00	Operating frequency ( Hz )	0.01 Hz
D0.01	Set frequency ( Hz )	0.01 Hz
D0.02	Bus voltage ( V )	0.1V
D0.03	Output voltage ( V )	1V
D0.04	Output current ( A )	0.01A
D0.05	Output power ( kW )	0.1kW
D0.06	Output torque ( % )	0.1%
D0.07	X Input Status	1
D0.08	MO 1 output status	1
D0.09	FIV Voltage ( V )	0.01V
D0.10	FIC Voltage ( V )	0.01V
D0.11	Reserve	
D0.12	Count value	1
D0.13	Length value	1
D0.14	Load speed display	1
D0.15	PID set up	0.1
D0.16	PID feedback	0.1
D0.17	PLC stage	1
D0.18	PULSE Input pulse frequency ( Hz )	0.01 kHz
D0.19	Feedback speed (unit)0.1 Hz	0.1Hz
D0.20	Remaining running time	0.1 Min
D0.21	FIV Voltage before correction	0.001V
D0.22	FIC Voltage before correction	0.001V
D0.23	Reserve	
D0.24	Linear velocity	1m/ Min
D0.25	Current power-on time	1 Min
D0.26	Current running time	0.1 Min
D0.27	PULSE Input pulse frequency	1Hz
D0.28	Communication settings	0.01%
D0.29	Reserve	

D0.30	Main frequencyX show	0.01 Hz
D0.31	Auxiliary frequencyY show	0.01 Hz
D0.32	View arbitrary memory address values	1
D0.33	Reserve	
D0.34	Reserve	
D0.35	Target torque ( % )	0.1%
D0.36	Reserve	
D0.37	Power factor perspective	0.1°
D0.38	Reserve	
D0.39	VF Separate target voltage	1V
D0.40	VF Separate output voltage	1V
D0.41	Reserve	
D0.42	Reserve	
D0.43	Reserve	
D0.44	Reserve	
D0.45	Fault Information	0

# Chapter 5 Troubleshooting and troubleshooting

## 5-1 Fault Alarm and Countermeasures

The NZSV frequency converter incorporates multiple warning messages and protective functions. Should a fault occur, the protective functions activate, causing the converter to cease output. The converter's fault relay contacts engage, and a fault code is displayed on the converter's control panel. Before seeking service, users may conduct self-checks following the guidance in this section to analyse fault causes and identify solutions. Should the cause fall within the dotted-line box description, please seek service by contacting either the distributor of your purchased inverter or our company directly.

Within fault information, OUOC denotes a hardware over-current or over-voltage signal. In most instances, hardware over-voltage faults trigger the OUOC alarm.

Fault 1 name	Inverter unit protection
Operation panel display	OC
Troubleshooting	<ol style="list-style-type: none"> <li>1.Short circuit in inverter output circuit</li> <li>2.Excessive wiring length between motor and frequency converter</li> <li>3.Module overheating</li> <li>4.Loose internal wiring of the frequency converter</li> <li>5.Main control board malfunction</li> <li>6.Driver board malfunction</li> <li>7.Inverter module malfunction</li> </ol>
Troubleshooting strategies	<ol style="list-style-type: none"> <li>1.Troubleshooting external faults</li> <li>2.Add a reactor or output filter</li> <li>3. Check if the air duct is blocked, and if the fan is working properly, and troubleshoot any problems.</li> <li>4.Plug in all the connecting cables</li> <li>5.Seeking technical support</li> <li>6.Seeking technical support</li> <li>7.Seeking technical support</li> </ol>
Fault2 name	Accelerating overcurrent
Operation panel display	OC 1
Troubleshooting	<ol style="list-style-type: none"> <li>1.The inverter output circuit has a grounding or short circuit.</li> <li>2.The control method is vector and no parameter identification is performed.</li> <li>3.Acceleration time is too short</li> <li>4.Manual torque boost orV/F The curve is not suitable</li> <li>5.Low voltage</li> <li>6.Start the rotating motor.</li> <li>7.Sudden load increase during acceleration</li> <li>8.The selected frequency converter is too small.</li> </ol>

Troubleshooting strategies	<ol style="list-style-type: none"> <li>1. Troubleshooting external faults</li> <li>2. Perform motor parameter identification</li> <li>3. Increase acceleration time</li> <li>4. Adjust the manual lifting torque or V/F curve</li> <li>5. Adjust the voltage to the normal range.</li> <li>6. Choose to start with speed tracking or wait for the motor to stop before starting.</li> <li>7. Cancel sudden load increases</li> <li>8. Select a frequency converter with a higher power rating.</li> </ol>
Fault3 name	Deceleration over-current
Operation panel display	OC 2
Troubleshooting	<ol style="list-style-type: none"> <li>1. The inverter output circuit has a grounding or short circuit.</li> <li>2. The control method is vector and no parameter identification is performed.</li> <li>3. The deceleration time is too short.</li> <li>4. Low voltage</li> <li>5. Sudden load application during deceleration</li> <li>6. No braking unit or braking resistor was installed.</li> </ol>
Troubleshooting strategies	<ol style="list-style-type: none"> <li>1 Troubleshooting external faults</li> <li>2 Perform motor parameter identification</li> <li>3 Increase deceleration time</li> <li>4 Adjust the voltage to the normal range.</li> <li>5 Cancel sudden load increases</li> <li>6 Add braking unit and resistor</li> </ol>
Fault4 Name	Constant speed overcurrent
Operation panel display	OC 3
Troubleshooting	<ol style="list-style-type: none"> <li>1 The inverter output circuit has a grounding or short circuit.</li> <li>2 The control method is vector and no parameter identification is performed.</li> <li>3 Low voltage</li> <li>4 Are there any sudden increases in load during operation?</li> <li>5 The selected frequency converter is too small.</li> </ol>
Troubleshooting strategies	<ol style="list-style-type: none"> <li>1 Troubleshooting external faults</li> <li>2 Perform motor parameter identification</li> <li>3 Adjust the voltage to the normal range.</li> <li>4 Cancel sudden load increases</li> <li>5 Select a frequency converter with a higher power rating.</li> </ol>

Fault5 Name	Accelerated overvoltage
Operation panel display	OU 1
Troubleshooting	1. Input voltage is too high 2. During acceleration, an external force drives the motor. 3 Acceleration time is too short 4. No braking unit or braking resistor was installed.
Troubleshooting strategies	1 Adjust the voltage to the normal range. 2. Cancel additional power or add braking resistor 3.Increase acceleration time 4. Add braking unit and resistor
Fault6 name	Deceleration over-voltage
Operation panel display	OU 2
Troubleshooting	1. Input voltage is too high 2. During deceleration, an external force drives the motor. 3.The deceleration time is too short. 4. No braking unit or braking resistor was installed.
Troubleshooting strategies	1 Adjust the voltage to the normal range. 2. Cancel additional power or add braking resistor 3. Increase deceleration time 4. Add braking unit and resistor
Fault7 Name	Constant speed overvoltage
Operation panel display	OU 3
Troubleshooting	1. Input voltage is too high 2. During operation, the motor is driven by an external force.
Troubleshooting strategies	1 Adjust the voltage to the normal range. 2. Cancel additional power or add braking resistor
Fault8 Name	Control power failure
Operation panel display	POF
Troubleshooting	1 .The input voltage is not within the range specified in the standard.
Troubleshooting strategies	1 Adjust the voltage to the specified range.
Fault9 name	Undervoltage fault
Operation panel display	LU

Troubleshooting	<ol style="list-style-type: none"> <li>1. Instantaneous power outage</li> <li>2. The inverter input voltage is not within the range required by the specification.</li> <li>3. Abnormal bus voltage</li> <li>4. The rectifier bridge and buffer resistor are not functioning properly.</li> <li>5. Driver board malfunction</li> <li>6. Control panel malfunction</li> </ol>
Troubleshooting strategies	<ol style="list-style-type: none"> <li>1. Reset fault</li> <li>2. Adjust the voltage to the normal range.</li> <li>3. Seeking technical support</li> <li>4. Seeking technical support</li> <li>5. Seeking technical support</li> <li>6. Seeking technical support</li> </ol>
Fault 10 Name	Inverter overload
Operation panel display	OL 2
Troubleshooting	<ol style="list-style-type: none"> <li>1. Is the load too large or is the motor stalled?</li> <li>2. The selected frequency converter is too small.</li> </ol>
Troubleshooting strategies	<ol style="list-style-type: none"> <li>1. Reduce the load and check the condition of the motor and machinery.</li> <li>2. Select a frequency converter with a higher power rating.</li> </ol>
Fault 11 name	Motor overload
Operation panel display	OL 1
Troubleshooting	<ol style="list-style-type: none"> <li>1. Motor protection parameters P9.01 Is the setting appropriate?</li> <li>2. Is the load too large or is the motor stalled?</li> <li>3. The selected frequency converter is too small.</li> </ol>
Troubleshooting strategies	<ol style="list-style-type: none"> <li>1. Set this parameter correctly.</li> <li>2. Reduce the load and check the condition of the motor and machinery.</li> <li>3. Select a frequency converter with a higher power rating.</li> </ol>
Fault 12 Name	Reserve
Operation panel display	Reserve
Troubleshooting	Reserve
Troubleshooting strategies	Reserve

Fault 13 Name	Output phase lossS
Operation panel display	LO
Troubleshooting	<ol style="list-style-type: none"> <li>1. The wiring from the frequency converter to the motor is faulty.</li> <li>2. The inverter's three-phase output is unbalanced when the motor is running.</li> <li>3. Driver board malfunction</li> <li>4. Module exception</li> </ol>
Troubleshooting strategies	<ol style="list-style-type: none"> <li>1. Troubleshooting external faults</li> <li>2. Check if the three-phase windings of the motor are normal and troubleshoot any faults.</li> <li>3. Seeking technical support</li> <li>4. Seeking technical support</li> </ol>
Fault 14 Name	Module overheating
Operation panel display	OH
Troubleshooting	<ol style="list-style-type: none"> <li>1. High ambient temperature</li> <li>2. Duct blockage</li> <li>3. Fan damage</li> <li>4. Module thermistor damaged</li> <li>5. Inverter module damaged</li> </ol>
Troubleshooting strategies	<ol style="list-style-type: none"> <li>1. Lower the ambient temperature</li> <li>2. Clean the air ducts</li> <li>3. Replace the fan</li> <li>4. Replace the thermistor</li> <li>5. Replace the inverter module</li> </ol>
Fault 15 Name	External faults
Operation panel display	EF
Troubleshooting	<ol style="list-style-type: none"> <li>1. Through multi-functional terminals S input external fault signal</li> </ol>
Troubleshooting strategies	<ol style="list-style-type: none"> <li>1. Reset operation</li> </ol>
Fault 16 name	Communication failure
Operation panel display	CE
Troubleshooting	<ol style="list-style-type: none"> <li>1. The host computer is not working properly.</li> <li>2. Communication line malfunction</li> <li>3. Communication parameters PD Incorrect group settings</li> </ol>
Troubleshooting strategies	<ol style="list-style-type: none"> <li>1. Check the wiring of the host computer.</li> <li>2. Check the communication connection cable</li> <li>3. Correctly set communication parameters</li> </ol>
Fault 17 name	Contacteur failure
Operation panel display	rAy
Troubleshooting	<ol style="list-style-type: none"> <li>1. The driver board and power supply are not working properly.</li> <li>2.1. Contactor malfunction</li> </ol>

Troubleshooting strategies	1. Replace the driver board or power board. 2. Replace the contactor
----------------------------	---

Fault 18 Name	Current detection fault
Operation panel display	IE
Troubleshooting	1. Check for abnormalities in Hall effect devices. 2. Driver board malfunction
Troubleshooting strategies	1. Replace Hall effect device 2. Replace the driver board
Fault 19 name	Motor self-learning fault
Operation panel display	TE
Troubleshooting	1. Motor parameters are not set according to the nameplate. 2. Parameter identification process timed out
Troubleshooting strategies	1. Set the motor parameters correctly according to the nameplate. 2. Check the leads from the frequency converter to the motor.
Fault 20 name	Reserve
Operation panel display	Reserve
Troubleshooting	Reserve
Troubleshooting strategies	Reserve
Fault twenty one name	EEPROM Read/write failure
Operation panel display	EEP
Troubleshooting	1. EEPROM chip damage
Troubleshooting strategies	1. Replace the main control board
Fault twenty two name	Inverter hardware failure
Operation panel display	OUOC
Troubleshooting	1. Overvoltage exists 2. Overcurrent exists
Troubleshooting strategies	1. Handling overvoltage faults 2. Handling overcurrent faults
Fault twenty three name	Short circuit to ground fault
Operation panel display	GND
Troubleshooting	1. Motor to ground short circuit
Troubleshooting strategies	1. Replace the cable or motor
Fault 26 name	Accumulated running time reaches fault

Operation panel display	END 1
Troubleshooting	1. The cumulative running time has reached the set value.
Troubleshooting strategies	1. Use the parameter initialization function to clear the log information.
Fault29 Name	The cumulative power-on time has reached the fault.
Operation panel display	END 2
Troubleshooting	1.The cumulative power-on time has reached the set value.
Troubleshooting strategies	1.Use the parameter initialization function to clear the log information.
Fault30 name	Loading failure
Operation panel display	LOAD
Troubleshooting	1.The inverter operating current is less than P9.64
Troubleshooting strategies	1. Confirm whether the load is disconnected or whether the P9.64 and P9.65 parameter settings match the actual operating conditions.

Fault31 name	Runtime PID Feedback loss fault
Operation panel display	PIDE
Troubleshooting	1.PIDFeedback less than PA .26 Setting value
Troubleshooting strategies	1.Examine PID Feedback signals or settings PA .26 is a suitable value
Fault40 name	Wave-by-wave current limiting fault
Operation panel display	CBC
Troubleshooting	1. Is the load too large or is the motor stalled? 2. The selected frequency converter is too small.
Troubleshooting strategies	1. Reduce the load and check the condition of the motor and machinery. 2. Select a frequency converter with a higher power rating.
Fault42 name	Excessive speed deviation fault
Operation panel display	ESP
Troubleshooting	1. No parameter self-learning was performed.
Troubleshooting strategies	1. Perform self-learning of motor parameters
Fault43 name	Motor overspeed fault
Operation panel display	oSP
Troubleshooting	1 No parameter self-learning was performed.
Troubleshooting strategies	1 No parameter self-learning was performed.

Fault51 name	Reserve
Operation panel display	Reserve
Troubleshooting	Reserve
Troubleshooting strategies	Reserve

## 5-2 Common Faults and Their Troubleshooting Methods

The following faults may occur during the use of the frequency converter. Please refer to the following methods for simple fault analysis:

Serial Number	Fault phenomenon	Possible reasons	Solution
1	No display after power-on	<p>The mains voltage is either absent or too low;</p> <p>The switching power supply on the inverter driver board is faulty; the rectifier bridge is damaged.</p> <p>The inverter's buffer resistor is damaged;</p> <p>Control panel and keyboard malfunction;</p> <p>The connection between the control board, driver board, and keyboard is broken;</p>	<p>Check the input power supply;</p> <p>Check the bus voltage;</p> <p>Seeking manufacturer services;</p>
2	The power-on display shows "2000".	<p>Poor contact in the wiring between the driver board and the control board; damage to relevant components on the control board;</p> <p>There is a short circuit to ground in the motor or motor wiring; Hall effect fault.</p> <p>The mains voltage is too low;</p>	<p>Seeking manufacturer services;</p>
3	Power-on display "GND" alarm	<p>Short circuit to ground in the motor or output line;</p> <p>inverter failure;</p>	<p>Use a megohmmeter to measure the insulation of the motor and output wires;</p> <p>Seeking manufacturer services;</p>
4	Power-on frequency converter show Normal, it displays after running. "2000" and immediately shut down.	<p>The fan is damaged or stalled;</p> <p>There is a short circuit in the wiring of the external control terminals;</p>	<p>Replace the fan;</p> <p>Eliminate external short-circuit faults;</p>

5	Frequent reports OH (IGBT) overheat Fault	The carrier frequency setting is too high. The fan is damaged or the air duct is blocked. Internal components of the frequency converter are damaged.	Reduce the carrier frequency ( P0). 15 ). Replace the fan and clean the air duct. Seek manufacturer service.
6	After the frequency converter is running , the power The machine is not turning .	Motor and motor wire; Inverter parameter settings are incorrect (motor parameters ); poor contact in the wiring between the drive board and the control board; Driver board failure;	Reconfirm the wiring between the frequency converter and the motor; Replace the motor or clear the mechanical fault; Check and reset the motor parameters;
7	S Terminal failure.	Incorrect parameter settings; External signal error; Control board malfunction; NPN / PNP The jumper switch is in the wrong position;	Check and reset P5 group related parameters ; Reconnect the external signal cable; Seeking manufacturer services; Correct settings NPN / PNP The position of the jumper switch ;
8	Reserve	Reserve	Reserve
9	The frequency converter frequently reports over-current and overvoltage faults.	The motor parameters are set incorrectly. The acceleration and deceleration times are inappropriate; Load fluctuations;	Reset the motor parameters or perform motor self-learning; Set appropriate acceleration and deceleration times; seek manufacturer support.
10	Power on (or running ) report rAY	The contactor did not engage;	Check if the contactor cable is loose; Check the contactor for malfunctions; check the contactor. bthere a fault in the 24V power supply ? Seeking manufacturer services;

# Chapter 6 Maintenance and upkeep



- Maintenance personnel must perform maintenance and upkeep according to the specified methods.
- Maintenance personnel must be qualified professionals.
- Before performing maintenance, the power supply to the frequency converter must be disconnected, and maintenance work can only be carried out after 10 minutes.
- Do not touch directly. Components on the PCB board are susceptible to damage from static electricity, otherwise the inverter may be easily damaged.
- After the repair is completed, you must make sure that all screws are tightened.

## 6-1 Routine maintenance

To prevent inverter failures, ensure normal equipment operation, and extend the inverter's service life, routine maintenance is necessary .The routine maintenance tasks are as follows:

Inspection items	Content
Temperature / Humidity	Confirm the ambient temperature is 0 ° ~40 ° , Humidity at 20-90% and no condensation
oil mist and dust	Confirm that there is no oil mist, dust, or condensation inside the frequency converter.
frequency converter	Check the frequency converter for abnormal heating and vibration.
fan	Confirm that the fan is working properly and there are no obstructions or other issues.
Input power	Confirm that the voltage and frequency of the input power supply are within the allowable range.
Motor	Check the motor for abnormal vibration, overheating, abnormal noise, and phase loss.

## 6-2 Regular maintenance

To prevent faults in the frequency converter and ensure its long-term, high-performance, stable operation, users must conduct regular inspections (at intervals of no more than six months). The inspection items are as follows:

Inspection items	Inspection content	Elimination methods
Screws for external terminals	Are the screws loose	Tighten
PCB plate	Dust, dirt	Use dry compressed air to thoroughly remove debris.
Fan	the abnormal noise and vibration, and the cumulative time, exceed 2 10,000 hours	1.Remove debris 2. Replace the fan

Electrolytic capacitors	Does it change color Does it have an unusual odor	Replace electrolytic capacitor
Heat sink	Dust, dirt	Use dry compressed air to thoroughly remove debris.
Power components	Dust, dirt	Use dry compressed air to thoroughly remove debris.

### **6-3 Replacement of vulnerable parts of frequency converter**

Fans and electrolytic capacitors within frequency converters are components prone to failure. To ensure the long-term, safe, and trouble-free operation of the converter, these vulnerable parts must be replaced periodically. The recommended replacement intervals are as follows:

- ◆ Fan: Replacement required after exceeding 20,000 hours of operation
- ◆ Electrolytic capacitor: Replacement required after 30,000 to 40,000 hours of operation

### **6-4 Inverter warranty**

Our companyThe NZSV series frequency converters are available from the date of manufacture. 12 -month warranty service.

# Chapter 7 External accessories selection

Name	Function
Air and residual current circuit breakers	Protect the inverter's wiring for easy installation, maintenance, and upkeep.
electromagnetic contactor	To facilitate the switching of the frequency converter and power supply, ensuring safety.
Surge absorber	Absorbing surge currents from relays used for electromagnetic contact and control
Isolation transformer	It isolates the input and output of the frequency converter, reducing interference.
DC reactor	Protect the frequency converter and suppress high-order harmonics.
AC reactor	Protects the frequency converter, suppresses high-order harmonics, and prevents surge voltage impacts.
Braking resistor, braking unit	Absorb and regenerate energy
Noise filter	Reduce electromagnetic interference caused by frequency converters
Magnetic ring	Reduce electromagnetic interference caused by frequency converters

## 7-1 Braking resistor

Inverter Model	Braking resistor		Braking unit CDBR	Braking torque (10%ED)	Applicable motors (KW)
	powerW	resistance $\Omega (\geq)$			
NZSV-0R7G-T2-B1	80	150	built-in	125	0.75
NZSV-1R5G-T2-B1	100	100			1.5
NZSV-2R2G-T2-B1	100	70			2.2
NZSV-0R7G-T4-B1 (2)	250	300			0.75
NZSV-1R5G-T4-B1 (2)	300	220			1.5
NZSV-2R2G-T4-B1 (2)	400	200			2.2
NZSV-3R7G-T4-B1 (2)	500	130			3.7
NZSV-5R5G-T4-B1 (2)	800	90			5.5
NZSV-7R5G-T4-B1 (2)	1000	65			7.5
NZSV-11G-T4-B2	1500	43			11
NZSV-15G-T4-B2	2000	32			15
NZSV-18.5G-T4-B2	4000	24			18.5
NZSV-22G-T4-B2	4500	24			22
NZSV-30G-T4-B2	6000	19.2			30
NZSV-37G-T4-B2	7000	14.8			37
NZSV-45G-T4-B2	9000	12.8			45

NZSV-55G-T4-B2	11000	9.6		55
NZSV-75G-T4-B2	15000	6.8		75
NZSV-90G-T4-B2	9000*2	9.3*2		90
NZSV-110G-T4-B2	11000*2	9.3*2		110
NZSV-132G-T4-B2	13000*2	6.2*2		132
NZSV-160G-T4-B2	16000*2	6.2*2		160

Note: \*2 indicates that two braking units are used in parallel with their respective braking resistors.  
Braking resistor calculation :

The braking resistor value is related to the DC voltage during inverter braking. For example : 380V The power supply level is 800V-820V DC during braking .220V system, DC voltage is400V .

Additionally, braking resistance and braking torqueThe braking resistance value is related to Mbr% , and different braking torques result in different braking resistance values. The calculation formula is as follows :

$$R = \frac{U_{dc} \times \%}{P_{电数} \times Mbr\% \times \eta_{变频器} \times \eta_{电机}}$$

U dc --- Braking DC voltage

P Electrical data - motor power

Mbr ---- Braking torque

$\eta$ Motor ----- Motor Efficiency

$\eta$  frequency converter ----- frequency converter efficiency

Braking power is related to braking torque and braking frequency. The braking torque given in the table above is 125% and the frequency is 10%. Due to different load conditions, the data in the table is for reference only.

# Appendix 1 NZSV Modbus Communication Protocol

NZSV Series inverters provide RS 485 communication interface, and supports Modbus Communication protocol. Users can access it via computer or... PLC This enables centralized control, allowing users to set inverter operation commands, modify or read function code parameters, and read the inverter's operating status and fault information via the communication protocol.

## I. Agreement Content

This serial communication protocol defines the content and format of information transmitted in serial communication. This includes : the master polling (or broadcast) format; the master's encoding method, which includes: the function code requesting the action, the transmitted data, and error checking, etc. The slave's response uses the same structure, including: action confirmation, returned data, and error checking, etc. If the slave encounters an error while receiving information, or is unable to complete the action requested by the master , it will organize a fault message as a response and send it back to the master.

## II. Application Methods

Inverter access has RS 485 " Single Master, Multiple Slave " PC / PLC Bus Control network.

## III. Bus Structure

### ( 1 ) Interface method

RS 485 hardware interface

( 2 ) Transmission method: asynchronous serial, half-duplex transmission. At any given time, only one of the master and slave devices can send data while the other can only receive data. In the serial asynchronous communication process, data is sent frame by frame in the form of messages.

( 3 ) Topology: Single-master, multi-slave system. Slave address configuration range: 1~247 , 0 This is the broadcast communication address. The slave address in the network must be unique.

## IV. Agreement Description

NZSV The series frequency converter communication protocol is an asynchronous serial master-slave protocol. Modbus In a communication protocol, only one device (the host) in a network can establish a protocol (called a " query / command " ). Other devices (slaves) can only respond to the host's " queries / commands " by providing data, or perform corresponding actions based on the host's " queries / commands " . Here, the host refers to a personal computer ( PC ), industrial control equipment, or programmable logic controller ( PLC ), etc., while the slave refers to NZSV Frequency converter. The master unit can communicate with a single slave unit individually, or broadcast information to all slave units. For individual access to the master unit, a " query / command " function is used. The slave device must return a message (called a response ) . For broadcast messages sent by the master device, the slave device does not need to send a response back to the master device.

## V. Communication Data Structure

NZSV Series frequency converters Modbus The protocol communication data format is as follows: Using RTU The pattern is that message sending must at least use... The pause interval begins after 3.5 character duration.

This is the easiest to implement at various character times under network baud rates. The first field transmitted is the device address.

The transmittable characters are in hexadecimal format. 0...9,A...F Network devices continuously monitor the network bus, including during pause intervals. When the first field (address field) is received, each device decodes it to determine if it's destined for itself. After the last transmitted character, at least one... A pause of 3.5 characters marks the end of the message. A new message can begin after this pause.

The entire message frame must be transmitted as a continuous stream. If there are more than [number] messages before the frame is complete, [the message will be transmitted as a continuous stream]. A pause of 1.5 character timestamps means the receiving device will refresh the incomplete message and assume the next byte is the address field of a new message. Similarly, if a new message is less than... If a message continues immediately after the previous message within a 3.5-character time interval, the receiving device will interpret it as a continuation of the previous message. This will result in an error because of the final CRC... The value of the field cannot be correct.

### RTU Frame format:

Frame header START	3.5 character time
Slave address ADR	Mailing address: 1~247
command code CMD	03 : Read slave parameters; 06 : Write slave parameters
Data content DATA	Contents of the document: Function code parameter address, number of function code parameters, function code parameter value, etc.
Data content DATA	
Data content DATA 0	
CRC CHK high level	Detected value: CRC value.
CRC CHK low position	
END	3.5 character time

### CMD (command commands) and DATA (data description)

Command code: 03H Read N words (maximum number of words that can be read) (12 characters) For example: slave address is The starting address of the frequency converter 01 F105 Continuous Reading Two values.

### Host command information

ADR	01H
CMD	03H
High bits of the starting address	F1H
Starting address low bits	05H
Number of registers (high-order bits)	00H
Register count (low byte)	02H
CRC CHK low position	Its calculation is pending. CRC CHK value
CRC CHK high level	

### Response information from the machine

ADR	01H
CMD	03H
Number of bytes	04H
Material F002H high level	00H

MaterialF002H low position	00H
MaterialF003H high level	00H
MaterialF003H low position	01H
CRC CHK low position	Its calculation is pending. CRC CHK value
CRC CHK high level	

Command code: 06H Write a word. For example, write 3000 (BB8H) to the slave address 05H of the inverter at address F00AH.

#### Host command information

ADR	05H
CMD	06H
Data address high byte	F0H
Data address low bits	0 AH
High level of data content	0 BH
Data content at a low level	B8H
CRC CHK low position	To be calculated CRC CHK value
CRC CHK high level	

#### Response information from the machine

ADR	02H
CMD	06H
Data address high byte	F0H
Data address low bits	0 AH
High level of data content	13H
Data content at a low level	88H
CRC CHK low position	To be calculated CRC CHK value
CRC CHK high level	

Verification method – CRC Verification method: CRC ( Cyclical) Redundancy Check ) Use RTU Frame format, the message includes based on CRC Error detection domain of the method. CRC The domain inspected the entire message content. CRC A field is two bytes and contains A 16- bit binary value. It is calculated by the transmitting device and added to the message. The receiving device recalculates the received message. CRC and with the received CRC Comparing values in a domain, if twoCRC If the values are not equal, it indicates that there is a transmission error.

CRC First deposit 0xFFFF , Then call a procedure to process the consecutive messages. The 8-bit byte is processed in conjunction with the value in the current register . Only 8 bits of each character are processed. Data pairs CRC Valid, but the start bit, stop bit, and parity bit are invalid.

CRC During the generation process, each ~~Each of the~~ 8 characters is individually XOR with the register contents , and the result is shifted towards the least significant bit . Move to the left, with the most significant bit as 0 -fill. LSB If it is extracted and tested, LSB for 1 The register is XOR with the preset value individually , if LSB for 0 If not, then it will not proceed . The entire process will be repeated 8 times. After the last digit (the 8th digit) is completed, the next digit will be... ~~Each~~ 8-bit byte is then XOR separately with the current value of the register . The final value in the register is the result of all bytes in the message being executed. CRC value.

CRC When adding to a message, the low byte is added first, followed by the high byte.

CRC The simple function is as follows:

```

unsigned int crc_cal_value(unsigned char *data_value,unsigned char data_length)
{
int i ;
unsigned int crc_value = 0xffff ;
while ( data _ length --)
{
crc_value^=*data_value++;
for(i=0;i<8;i++)
{
if(crc_value&0x0001)
crc_value=(crc_value>>1)^0xa001;
else
crc_value=crc_value>>1;
}
}
Return ( crc _ value ); }

```

Address definition for communication parameters:

This section constitutes the communication content, used to control the operation of the frequency converter, monitor its status, and configure relevant parameters. Read/write function code parameters (some function codes are non-modifiable, reserved for manufacturer use or monitoring purposes), with the following addressing convention for function code parameters: Parameter addresses are denoted using the function code group number and identifier:

High byte: F0–FF (P group), A0–AF (C group), 70–7F (D group)

Low byte: 00–FF

Example: P3.12 is represented as address F30C. Note: PF group: Parameters cannot be read or modified. D group: Parameters are read-only.

Certain parameters cannot be modified while the inverter is operational; others remain inaccessible regardless of the inverter's state. When altering function code parameters, observe the parameter range, units, and associated notes.

Furthermore, frequent EEPROM storage reduces its lifespan. Consequently, some function codes require no EEPROM storage in communication mode; modifying the RAM value suffices.

For P-group parameters, to implement this function, simply change the high-order bit F of the function code address to 0. For L-group parameters, to implement this function, simply change the high-order bit A of the function code address to 4. The corresponding function code addresses are represented as follows: High byte: 00–0F (P group), 40–4F (C group) Low byte: 00–FF

For example: Function code P3.12 is not stored in EEPROM, represented by address 030C; Function code C0.05 is not stored in EEPROM, represented by address 4005. This address representation permits only RAM write operations; read operations are invalid and will be treated as an invalid address.

Stop/Run Parameter Section:

Parameter address	Parameter Description
1000	* Communication settings ( -10000~) 10000 ( decimal)
1001	Operating frequency
1002	Bus voltage
1003	Output voltage
1004	Output current

1005	Output power
1006	Output torque
1007	Running speed
1008	Input terminal markings
1009	Output terminal markings
100A	FIV Voltage
100B	FIC Voltage
100C	Reserve
100D	Count value input
100E	Length value input
100F	Load speed
1010	PID set up
1011	PID feedback
1012	PLC step
1013	PULSE Input pulse frequency, unit0.01 kHz
1014	Feedback speed, unit0.1 Hz
1015	Remaining running time
1016	FIV Voltage before correction
1017	FIC Voltage before correction
1018	Reserve
1019	Linear velocity
101A	Current power-on time
101B	Current running time
101C	PULSE Input pulse frequency, unit 1 Hz
101D	Communication settings
101E	Actual feedback speed
101F	main frequencyX show
1020	auxiliary frequencyY show

**\*\* Notice:**

The communication setting is a percentage of a relative value; 10000 corresponds to 100.00% - 10000 corresponds to -100.00% . For data in frequency units, this percentage is relative to the maximum frequency ( P0). 1 0 ) is a percentage; for data in the dimension of torque, this percentage is P2.10 .

Control commands input to the frequency converter : ( write only)

Command address	Command Function
2000	0001 : Forward rotation
	0002 : Reverse operation
	0003 : Forward jogging
	0004 : Reverse inching
	0005 :Free stop
	0006 : Deceleration and Stop
	0007 : Fault Reset

Read inverter status : ( Read-only)

Status word address	Status word function
3000	0001 : Forward rotation
	0002 : Reverse operation
	0003 : Shutdown

--	--

Parameter lock password verification : ( If the return value is...)8888H This means the password verification has passed.

Password address	Enter the password content
1F00	*****

command address	Command content
2001	BIT 0 : ( Reserved) BIT 1 : ( Reserved) BIT 2 : RA - RB - RC Output control BIT 3 : TA - TC Output control BIT 4 : YOR Output control

Analog output FOV Control : ( Write-only)

command address	Command content
2002	0 ~ 7 FFF express 0 % to 100 %

Analog Output FOC Control : ( Write-only)

command address	Command content
2003	0 ~ 7 FFF express 0 % to 100 %

Pulse output control : ( Write only)

command address	Command content
2004	0 ~ 7 FFF express 0 % to 100 %

Inverter fault description:

Inverter fault address	Inverter fault information
8000	0000 : No fault 0001 : Inverter Unit Protection 0002 : Accelerating overcurrent 0003 : Deceleration overcurrent 0004 : Constant-rate overcurrent 0005 : Accelerated overvoltage 0006 : Deceleration overvoltage 0007 : Constant-rate overvoltage 0008 : Control power supply failure 0009 : Undervoltage fault 000A : Inverter overload 000B : Motor overload 000C : Input phase loss 000D : Output phase loss 000E : Module overheating 000F : External Fault 0010 : Communication error 0011 : Contactor malfunction 0012 : Current detection fault 0013 : Motor self-learning fault 0014 : Encoder / PG Card malfunction 0015 : Parameter read/write error 0016 : Inverter hardware failure 0017 : Motor to ground short circuit fault 0018 : Reserved 0019 : Reserved 001A : Runtime reached 001B: reserve 001C: reserve 001D: Power-on time reached 001E : Loadout 001F : Runtime PID Feedback lost 0028 : Fast rate limiting timeout fault 0029 : Motor switching failure during operation; 002A: Excessive speed deviation. 002B : Motor overspeed 002D : Motor overheating 005A : Reserved 005B : Reserved 005C : Initial position error 005E : Reserved
Communication	Fault Function Description

Fault Address	
8001	0000 : No fault

	0001 : Incorrect password 0002 : Command code error 0003 : CRC Verification error 0004 : Invalid address 0005 : Invalid parameter 0006 : Parameter change is invalid 0007 : System locked 0008 : In progress EEPROM operate
--	--

PD Group communication parameter description

PD .00	baud rate	Factory value	0005
	Set range	Units: MODUBS baud rate 0: 300BPS 1: 600BPS 2: 1200BPS 3: 2400BPS 4: 4800BPS 5: 9600BPS 6: 19200BPS 7: 38400BPS 8 57600 BPS 9 115200 BPS	

This parameter sets the data transmission rate between the host computer and the frequency converter. Note that the baud rates set on the host computer and the frequency converter must be identical; otherwise, communication will fail. A higher baud rate results in faster communication.

PD .01	Data format	Factory value	3
	Set range	0 No validation: Data format <8,N,2> 1 Even test: Data format <8,E,1> 2 Odd parity: Data format <8, 0,1> 3 No validation: Data format <8,N, 1>	

The data formats set by the host computer and the frequency converter must be consistent; otherwise, communication will not be possible.

PD .02	Local address	Factory value	1
	Set range	1~247 , 0 For broadcast address	

When the local address is set to 0 When the address is set, it becomes the broadcast address, enabling the host computer to broadcast.

The local address is unique (except for the broadcast address ), which is the basis for realizing point-to-point communication between the host computer and the frequency converter.

PD .03	Response delay	Factory value	2 ms
	Set range	0~20 ms	

Response delay: refers to the time interval between the inverter finishing receiving data and sending data to the host computer. If the response delay is less than the system processing time, the response delay is based on the system processing time. If the response delay is longer than the system processing time, the system will wait after processing the data until the response delay time has elapsed before sending the data to the host computer.

PD .04	Communication timeout	Factory value	0.0 s
	Set range	0.0 s (invalid) 0.1~60.0s	

When the function code is set to 0.0 s At that time, the communication timeout parameter is invalid. When this function code is set to a valid value, if the interval between one communication and the next communication exceeds the communication timeout...

During this period, the system will report a communication failure error ( CE ). Normally, this is set to invalid. However, in systems with continuous communication , setting this parameter allows monitoring of the communication status.

PD .05	Communication protocol selection	Factory value	1
	Set range	1 Standard Modbus protocol	
PD .06	Communication reading current resolution Rate	Factory value	1
	Set range	0.01A 1: 0.1A	

Used to determine the output current when reading from the communication source. The unit for outputting current value.