

BLDL180 Low voltage DC brushless motor driver instruction manual

Key Features

- ◆ Current speed double closed-loop design, low speed high torque, smooth operation;
- ◆ High torque and high speed output, the maximum speed 8000rpm(according to the motor);
- ◆ Speed regulation mode: external PWM speed regulation or external potentiometer speed regulation;
- ◆ EN (enable), DIR (direction), X1 (brake) signal control terminal;
- ◆ With over current, over voltage, under voltage, Hall sensor phase error, motor blocking and other protection functions.



Product Overview

This DC brushless motor driver is the latest launched by our company, aiming at low-voltage DC brushless motor drive field of high-tech products. This product uses a large scale integrated circuit to replace the original hardware design, with higher anti-interference and fast response performance. This product is suitable for driving the peak current below 5A, the power supply voltage within DC24V~48V (panel nominal DC24V~48V) of any low-voltage Hall or no hall three-phase DC brushless motor, and has the characteristics of low temperature when working with high current. The product is used in a series of electrical automation control fields such as knitting equipment, medical equipment, food packaging machinery, power tools, etc.

Electrical performance index

Electrical performance (at ambient temperature $T_j=25^{\circ}\text{C}$)

Power supply	DC24V ~ 48V DC power supply (capacity selected according to motor power)
Maximum output current	Not more than 5A (depending on the motor and rated load)
Adapted motor	Suitable for motors with output power $\leq 180\text{W}$
Insulation resistance	$>500\text{M}\Omega$ at room temperature
Insulation strength	0.5KV at normal temperature and pressure for 1 minute

Use environmental parameters:

Cooling method	Natural air cooling & forced air cooling	
Use environment	Occasion	Try to avoid dust, oil mist and corrosive gases
	Temperature	$0^{\circ}\text{C} \sim +50^{\circ}\text{C}$
	humidness	$<80\%RH$, no condensation, no frost
	Vibration	$<0.5G$ (4.9m/s^2) 10Hz-60Hz(non-continuous operation)
Storage temperature	$-20^{\circ}\text{C} \sim +65^{\circ}\text{C}$	
Overall dimensions	96mm*57mm*28mm	
Weight	About 0.13Kg	

[Note] Due to the drastic change of storage and transportation environment temperature, it is easy to produce condensation or frost, at this time, the driver should be placed for more than 12 hours, until the driver temperature is consistent with the environmental temperature before power operation.

Port description

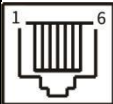
Features	Signage	Instructions														
Indicator light	POWER	Green power indicator. If the power is on, the power supply is normal														
	ALARM	<p>Red status indicator</p> <p>(1) The red light is off when normal;</p> <p>(2) when EN is not connected to GND1, the red light is steady on;</p> <p>(3) When the parameter storage fails, the red light flashes 1 time and stop for 1s;</p> <p>(4) When the under voltage fault occurs, the red light flashes 2 times and stops for 1s;</p> <p>(5) When the overvoltage fault occurs, the red light flashes 3 times and stops for 1s;</p> <p>(6) When the Hall signal is faulty, the red light flashes 4 times and stop for 1s;</p> <p>(7) When the motor is short circuit fault, the red light flashes 5 times and stop for 1s;</p> <p>(8) When the motor is blocked, the red light flashes 6 times and stops for 1s;</p> <p>(9) When the motor is overloaded, the red light flashes 7 times and stop for 1s;</p> <p>(10) When the motor speed is abnormal, the red light flashes 9 times and stop for 1s.</p>														
485 Communication port	RS485	<p>Can be connected to external handheld debugger, display speed, can also be used to set drive parameters.</p>  <table border="1" data-bbox="754 936 1358 1211"> <thead> <tr> <th>Pin number</th> <th>Signal</th> </tr> </thead> <tbody> <tr> <td>1</td> <td>NC</td> </tr> <tr> <td>2</td> <td>NC</td> </tr> <tr> <td>3</td> <td>485 +</td> </tr> <tr> <td>4</td> <td>COM</td> </tr> <tr> <td>5</td> <td>485 -</td> </tr> <tr> <td>6</td> <td>COM</td> </tr> </tbody> </table>	Pin number	Signal	1	NC	2	NC	3	485 +	4	COM	5	485 -	6	COM
Pin number	Signal															
1	NC															
2	NC															
3	485 +															
4	COM															
5	485 -															
6	COM															
Control signal	+5V	Control signal power supply positive (built-in power output)														
	VSP	<p>External speed control signal control mode:</p> <p>1, through the external potentiometer to change the VSP terminal voltage to achieve speed regulation, the range of 0~5.0V</p> <p>2, through the external frequency 50 Hz-300Hz, amplitude+5V PWM signal, change the PWM duty ratio to achieve speed regulation.</p>														
	X1	Brake signal input, low level brake, brake state red light is off (brake braking strength can be adjusted according to user requirements)														
	DIR	High and low level control motor forward and reverse, connected to GND1 motor reverse (counterclockwise), not connected to GND1 motor forward (clockwise)														
	EN	Motor enable control, EN connected to GND1, motor turn, EN not connected, motor do not turn (the state of the red light is on)														
	GND	Control signal ground														
Hall signal	+5V	Motor Hall power positive														
	HU	Hall sensor signal U phase input														
	HV	Hall sensor signal V phase input														
	HW	Hall sensor signal W phase input														
	GND	Motor Hall ground														
Motor and power	U, V, W	Motor three-phase output signal, connected to the motor														
	V+, GND	DC24V ~ 48V power supply input (do not reverse power polarity)														

Function Description

<p>Speed control mode selection (VSP/PWM)</p>	<p>1 External input speed control: The two fixed ends of the external potentiometer are connected to the GND and +5V of the driver, the adjustment end is connected to the VSP, User can use the external potentiometer (5K~10K) to regulate speed. User can also use other control units (such as PLC, MCU, etc) . VSP acceptance range of DC 0V~+5V, corresponding motor speed is 0~ rated speed.</p> <p>2 PWM speed regulation: PWM positive connect VSP, negative connect GND, input frequency should be greater than 50Hz (recommended 100Hz), change the duty ratio to regulate speed.</p>
<p>Brake braking (X1)</p>	<p>By controlling the conversion of the terminal X1, user can control the stop and operation of the motor. When X1 is low level, the motor stops running and the brake brakes, the red light is off; When X1 is not connected, the motor is allowed to run. (Brake braking force can be adjusted according to user requirements)</p>
<p>Motor forward/reverse signal (DIR)</p>	<p>By controlling the conversion of the terminal DIR, the forward and reverse rotation of the motor can be controlled.</p> <p>Note: In order to avoid sudden reversing when the motor is running at high speed, the huge impact on the motor and mechanical equipment, when the DIR end receives the reversing signal, the driver first slows down the motor until it stops, and after stopping for about 1S, the motor changes direction and increases the speed to the set speed.</p>
<p>Motor start/Stop signal (EN)</p>	<p>The stop and operation of the motor can be controlled by controlling the conversion of the terminal EN. When EN is low level, the motor runs normally; When the EN is not connected, the motor stops working.</p>
<p>Alarm indication (ALM)</p>	<p>Output 5V high level (relative to GND) in normal operation, when there is overvoltage, overcurrent, Hall signal error, motor blocking, this signal is 0V (relative to GND).</p>

Wiring Diagram

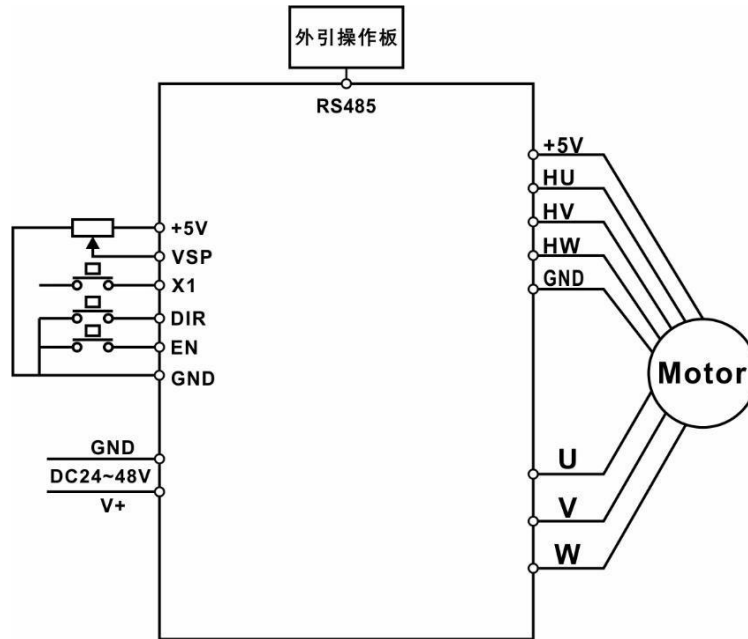

Dimensions (unit: mm)

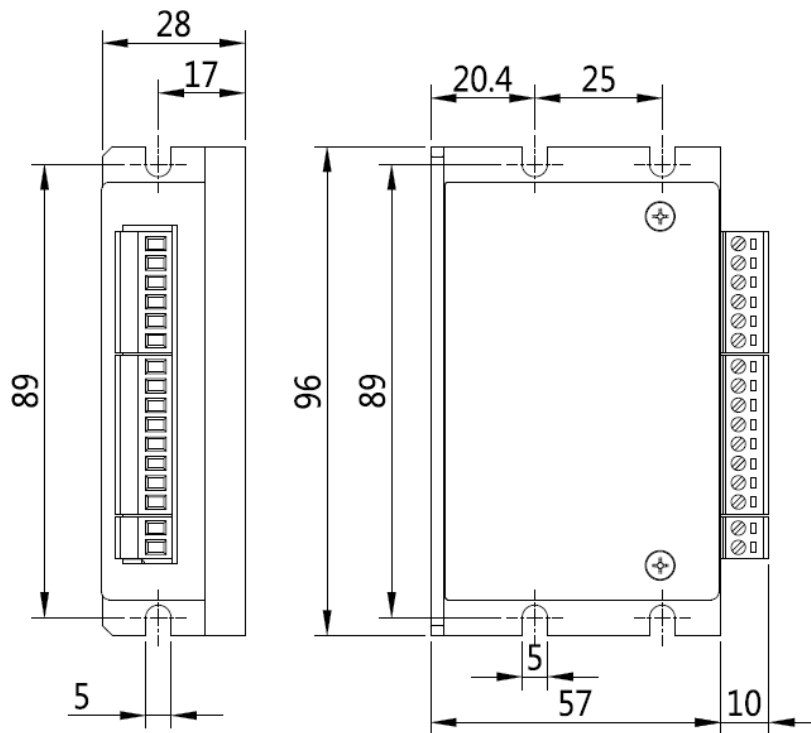











Safety matters

- ★ Motor and driver wiring must be carried out in the state of power off, do not live wiring.
- ★ According to the method shown, correctly connect the power cord, motor winding wire and Hall signal wire, pay attention to the sequence of U,V,W three-phase and Hall signal HU,HV,HW must be consistent
- ★ Do not disassemble the driver at will to prevent device damage
- ★ Do not touch any terminal during power-on operation
- ★ Do not run the driver without a housing
- ★ Striking the drive may cause damage

Accessories:Low voltage brushless external lead box Operating instructions

1, the outer box key operation instructions

If the handshake is successful, the monitoring parameters in dP zone will be displayed. If the handshake is not successful, it will display -Econ -. You can adjust the parameters you want to monitor by pressing the  and . Long press  can switch to the parameter setting interface to display PX-XX, by  selecting the bit to be set, by  and  setting parameters, press the key  to enter the parameter setting interface, by  selecting the bit to be set, by  setting parameters, press  to save the parameter setting, if press  to exit the parameter setting, parameters are not saved.

2, parameter table

Function codes	Name	Range	Default	Parameter Description
P0-00	System version			
P0-01	Restore factory values	0 ~ 1	0	
P0-02	Operate panel to set speed	50 ~ 10000	50	
P0-03	Acceleration time	1-2000	30	Unit: 0.1S
P0-04	Deceleration time	1-2000	30	Unit: 0.1S
P0-05	Motor speed rating	100 ~ 10000	3000	
P0-06	Motor pole number	1 ~ 32	2	
P0-07	Brake ratio	10 to 100	30	
P0-08	Speed command source	0 ~ 2	0	0: External potentiometer input 1: Operating panel Settings 2: 485 Communication Settings
P0-09	Potentiometer filter factor 1	0 ~ 1000	5	
P0-10	Potentiometer filter factor 2	0 ~ 100	5	
P0-11	External terminal filter factor 1	0 ~ 1000	10	
P0-12	External terminal filtering coefficient 2	0 ~ 1000	2	
P0-13	Machine station number	1-250	1	

P0-14	Communication format	0 ~ 1	0	0:8,N,1 1:8,N,2
P0-15	Communication baud rate	0 ~ 4	2	0:2400 1:4800 2:9600 3:19200 4:38400
P0-16	Bus current Settings	1-100	25	Unit: 0.1A
P0-17	Open loop closed loop selection	0 ~ 3	0	0: Inductive closed loop 1: inductive open loop 2:non-inductive closed loop 3:non-inductive open loop
P0-18	Open-loop duty cycle	5 ~ 96	5	
P0-20	Reverse dead zone time	0 ~ 1000	10	Unit: 0.1S
P0-21	Open loop blocking protection	0 ~ 1	0	0: The blocking protection is effective in open loop mode 1: The blocking protection is invalid in open loop mode
P0-22	Motor control period T	1-1000	20	Unit: ms
P0-24	Motor control ratio P	0 ~ 1000	11	
P0-25	Motor control integral I	1-10000	3	
P0-28	Motor control integral I (Speed prediction)	1-10000	10	Velocity prediction integral coefficient
P0-29	Motor control proportional limiting	0 ~ 1500	180	
P0-30	Non-inductive starting torque	0 ~ 1000	70	
P0-31	Non-inductive starting speed	1-500	4	

3, monitor the display interface

dP-00	Bus voltage
dP-01	Bus current
dP-02	Potentiometer voltage
dP-03	Running speed
dP-04	Error code
dP-05	Drive Running status

BLDL180 Low voltage DC brushless driver communication protocol

The communication mode uses the standard Modbus RTU protocol. The communication format can be changed by parameter P0-14 and the communication baud rate can be changed by parameter P0-15. If you want 485 communication control drive, you need to change the parameter P0-08 to 2.

The communication parameter addresses are as follows (all in decimal)

Function codes	Address	Name	Range	Default	Parameter Description
P0-00	0	System version			
P0-01	1	Restore factory values	0 ~ 1	0	
P0-02	2	Operate panel to set speed	50 ~ 10000	50	Unit: RPM
P0-03	3	Acceleration time	1-2000	30	Unit: 0.1 S
P0-04	4	Deceleration time	1-2000	30	Unit: 0.1 S
P0-05	5	Motor speed rating	100 ~ 10000	3000	Unit: RPM
P0-06	6	Motor pole number	1 ~ 32	2	
P0-07	7	Brake brake ratio	10 to 100	30	
P0-08	8	Speed command set source	0 ~ 2	0	
P0-09	9	Potentiometer filter coefficient 1	0 ~ 1000	5	
P0-10	10	Potentiometer filter factor 2	0 ~ 100	5	
P0-11	11	External terminal filter factor 1	0 ~ 1000	10	
P0-12	12	External terminal filter factor 2	0 ~ 1000	2	
P0-13	13	Machine station number	1-250	1	
P0-14	14	Communication format	0 ~ 1	0	
P0-15	15	Communication baud rate	0 ~ 4	2	
P0-16	16	Bus current Settings	1-100	24	Unit: 0.1 A
P0-17	17	Open loop closed loop selection	0 ~ 1	0	
P0-18	18	Open-loop duty cycle	5 ~ 96	5	
P0-20	20	Reverse dead zone time	0 ~ 1000	10	Unit: 0.1S
P0-21	21	Open loop blocking protection	0 ~ 1	0	0: The blocking protection is effective in open loop mode 1: The blocking protection is invalid in open loop mode
P0-22	22	Motor control period T	1-1000	20	Unit: ms
P0-24	24	Motor control ratio P (low speed)	0 ~ 1000	11	
P0-25	25	Motor control Integral I (low speed 1)	1-10000	3	
P0-28	28	Motor control Integral I (Low speed 2)	1-10000	10	
P0-29	29	Motor control proportional limiting	0 ~ 1500	180	

P0-30	30	Non-inductive starting torque	0 ~ 1000	70	
P0-31	31	Non-inductive starting speed	1-500	4	

The running status address (all in decimal)

Address	Name	Unit
200	Bus voltage	V
201	Bus current	0.1 A
203	Running speed	RPM
204	Error code	

Run command address (all in decimal)

Address	Name	Range
1000	Motor start-stop control	0: stop 1: r run
1001	Motor running direction	0: forward 1: reverse

Addresses 0 are read-only, 1 to 31 are read and write, 200 to 204 are read-only, and 1000 to 1001 are write-only.

Example:

Motor run: 01 06 03 E8 00 01 C8 7A

Motor stop: 01 06 03 E8 00 00 09 BA

Motor speed is set to 1000RPM: 01 06 00 02 03 E8 28 B4

Read actual motor speed: 01 03 00 CB 00 01 F5 F4