



NIETZ

Brushless Resolver

全球专业旋变供应商
Global Resolver Supplier



NIETZ ELECTRIC CO.,LTD

No.988, Fulian Rd. Gucun
Industry, Baoshan District.
Shanghai, China



Follow Us

+86 21 336 346 49

info@nietz.cn

www.nietz.cn



DISTRIBUTORS

中国·上海
China. Shanghai



NIETZ

» WHO WE ARE

Innovation +
Driving Tomorrow

NIETZ is one Leading Manufacturer of industrial automation products, with more than millions units sold worldwide, established 2005 Shanghai, China. We are committed to building long-lasting and successful business relations with our partners, has gained good reputation and deep influence.

We aim to provide the best quality, unmatched reliability and low price in our services and our products. We aim to reduce your costs, streamline manufacturing, to improve productivity.

The products of NIETZ are Variable Frequency Inverters, AC Servo System, Soft Starter, Planetary Gearboxes and Complete Device, The products NIETZ are technological advanced products and it has quite wide product range and already used widely in various applications such as textile machine, air compressor, hoist, packing machine, printing machine, electronic machine and other industries, which exported to over 40 countries and regions such as Europe, South America, Southeast Asia, Middle East and so on.

NIETZ always aims to be the professional driving solution provider and your mutual-benefit partner. «

Catalogue / 目录

◎ 单级或多级旋变

Single or multi pole pairs resolver

20系列 (20series)	P 03
26系列 (26series)	P 04
36系列 (36series)	P 05
52系列 (52series)	P 09
55系列 (55series)	P 11
68系列 (68series)	P 13
80系列 (80series)	P 14
86系列 (86series)	P 15
110系列 (110series)	P 16
140系列 (140series)	P 17
160系列 (160series)	P 18

◎ 高精度双通道旋变

High accurate two speed resolver

J45系列 (J45series)	P 19
J60系列 (J60series)	P 20
J80系列 (J80series)	P 21
J90系列 (J90series)	P 22
J106系列 (J106series)	P 23
J128系列 (J128series)	P 24
J158系列 (J158series)	P 25
J168系列 (J168series)	P 26
J200系列 (J200series)	P 27
J320系列 (J320series)	P 28

◎ 一体式旋变

Fabricated resolver

J20系列 (J20series)	P 29
J27系列 (J27series)	P 30
J51系列 (J51series)	P 31
J58系列 (J58series)	P 32

产品简介 Product introduction

绕线式旋变工作原理与普通变压器相似，通过定、转子绕组电磁耦合产生感生电动势，使输出绕组的感生电压随转子转角变化做相应的正弦或余弦变化的角度传感元件。广泛的应用于军工、航空航天、工业、伺服等领域。

The working principle of brushless resolver is similar to that of ordinary transformer. It is an angle sensing element that generates induced electromotive force through electromagnetic coupling of stator and rotor windings to make the induced voltage of output winding change sine or cosine with rotor angle change. It is widely used in military, aerospace, industrial, servo fields.

产品具有以下特点 The product has the following characteristics.

- 高精度的绝对式检测，适应高转速应用需求；
High precision absolute detection to meet the requirements of high speed applications.
- 结构紧凑、安装使用方便；
Compact structure, convenient installation and use.
- 可靠性高、寿命长、免维护、尤其适用于恶劣工况；
High reliability, long life, suitable for harsh environment, maintenance-free, especially for harsh working conditions;
- 性价比高；
High cost performance.
- 独有专利技术；
Unique patented technology.

电气原理 SCHEMATIC

旋转变压器是输出电压与转子转角成一定函数关系的特种电机，其一、二次侧绕组分别放在定、转子上，一次侧绕组与二次侧绕组之间的电磁耦合程度与转子的转角密切相关。

Resolver is a special motor with output voltage a function of the rotor angle. Its primary and secondary windings are placed on the stator and rotor respectively. The degree of electromagnetic coupling between the primary and secondary windings is closely related to the rotor angle.



图1-1 旋转变压器的绕组结构
(a)定子绕组 (b)转子绕组



安装说明 Installation

- 1、对于绕线式旋转变压器的安装，建议采用（间隙配合）：H7/h6与h6/H7；
For the fit condition of brushless resolver, it is recommended to adopt (transition fit):H7/h6与h6/H7;
- 2、电机转轴和旋变转子、定子轴中心的偏差一般要求 $\leq 0.03\text{mm}$ ；
The deviation between the motor shaft and the center of resolver rotor and stator shaft is generally required to be $\leq 0.03\text{mm}$;
- 3、电机端盖与旋变定子、电机转轴与旋变压器的配合端面垂直度 $\leq 0.05\text{mm}$ ；
The verticality of the mating end face between the motor end cover and the resolver stator, the motor shaft and the resolver rotor is $\leq 0.05\text{mm}$;
- 4、对于一体式旋转变压器（定子与转子已用轴承装配在一起），除上述要求外，电机转轴和旋变转子之间不能直接硬联接，而是需要经过专门的联轴节实现联接。
For the fabricated resolver (stator and rotor assembled together with bearings), in addition to the above requirements, the motor shaft and resolver rotor can not be directly connected forcibly, but need to be connected through a special coupling.

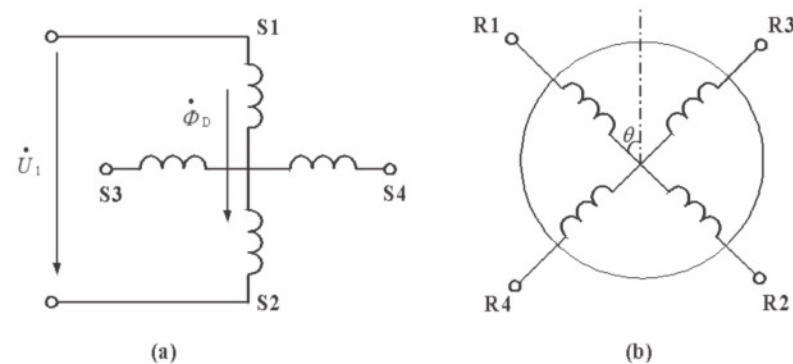
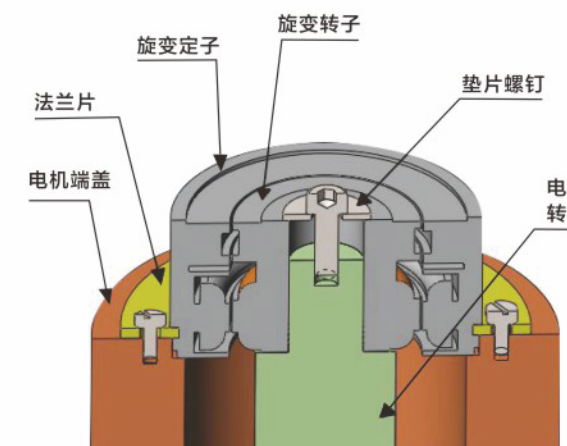
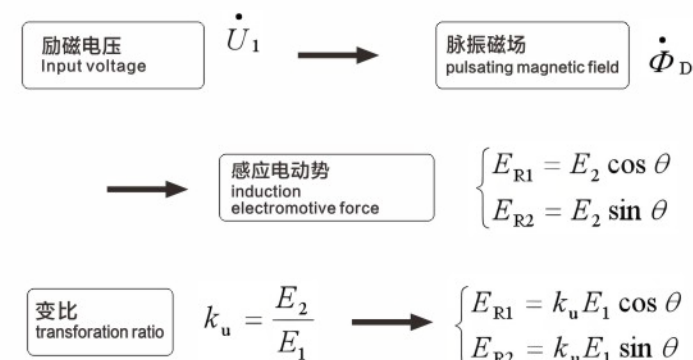
绕线式 | 20系列

Brushless resolver 20 series

J20XFW975 >>



绕线式 | 26系列

Brushless resolver 26 series

J26XFW975 >>

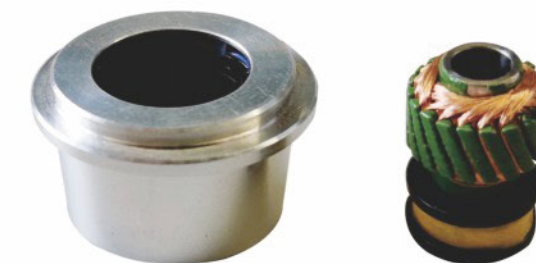

主要参数 main parameters

极对数 (Pole pairs)	1
激磁电压 (Input voltage)	AC 7Vrms
激磁频率(Input frequency)	10KHz
变压比 (Transformation ratio)	0.5 ± 10%
电气误差 (Accuracy)	± 10' max
相位移 (Phase shift)	15° ± 5°
输入阻抗(Input impedance)	(80 ± 12)Ω
输出阻抗(Output impedance)	(130 ± 20)Ω
耐电压(Dielectric strength)	AC 500Vrms 1min
绝缘电阻(Insulation resistance)	100MΩ MIN
允许最大转速(Max operating speed)	20000 rpm
工作温度范围(Operating temperature range)	-55℃ ~ +155℃
备注(Note)	转子内径可根据用户需求定制 (Rotor ID could be customized.)

主要参数 main parameters

极对数 (Pole pairs)	1
激磁电压 (Input voltage)	AC 7Vrms
激磁频率(Input frequency)	10KHz
变压比 (Transformation ratio)	0.5 ± 10%
电气误差 (Accuracy)	± 10' max
相位移 (Phase shift)	0° ± 10°
输入阻抗(Input impedance)	≥ 100Ω
输出阻抗(Output impedance)	≤ 350Ω
耐电压(Dielectric strength)	AC 500Vrms 1min
绝缘电阻(Insulation resistance)	100MΩ MIN
允许最大转速(Max operating speed)	20000 rpm
工作温度范围(Operating temperature range)	-55℃ ~ +155℃
备注(Note)	转子内径可根据用户需求定制 (Rotor ID could be customized.)

外形及安装尺寸图 Outline(dimension:mm)

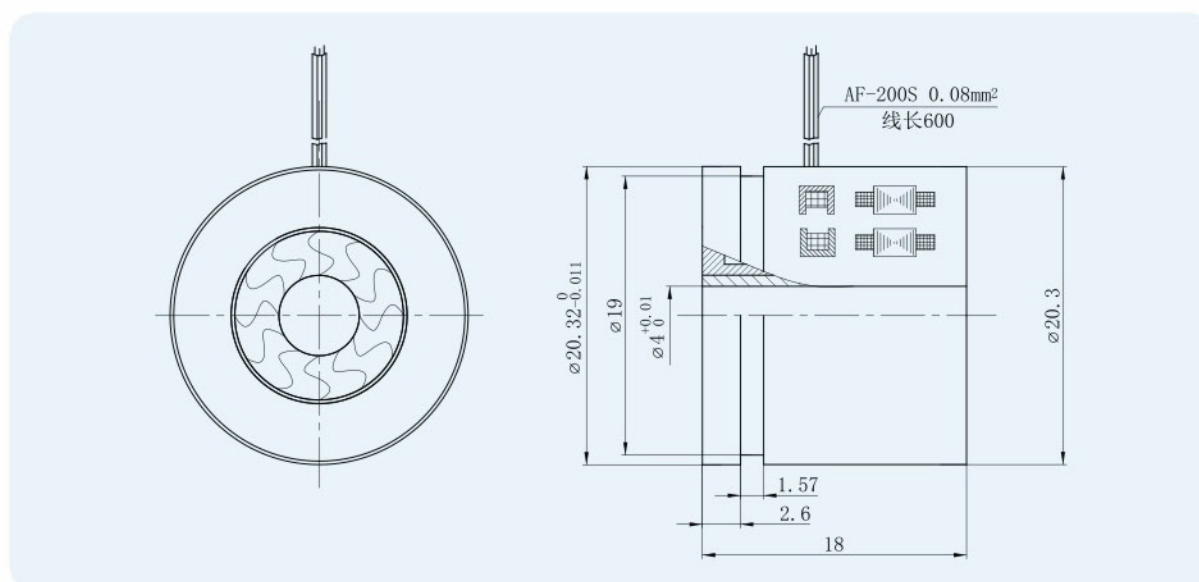

外形及安装尺寸图 Outline(dimension:mm)

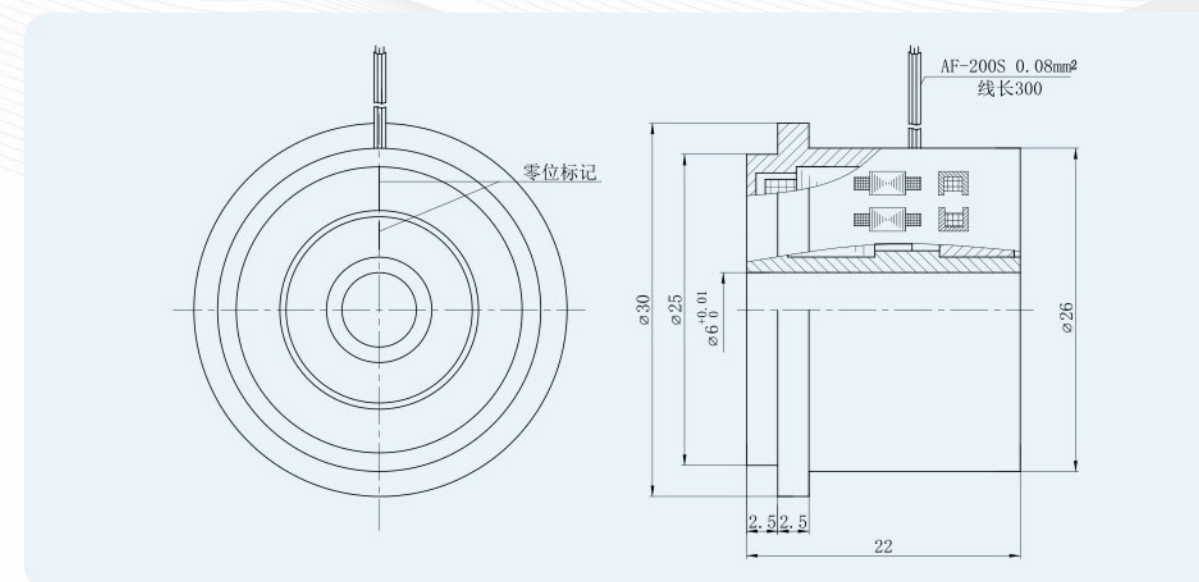

绕线式 | 36系列

Brushless resolver 36 series



绕线式 | 36系列

Brushless resolver 36 series

J36XFW975M >>

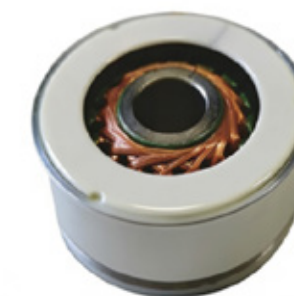

主要参数

main parameters

型号 (Type)	J36XFW975BX	J36XFDW9752	J36XFDW9753	J36XFDW9754
极对数 (Pole pairs)	1	2	3	4
激磁电压 (Input voltage)	AC 7Vrms	AC 7Vrms	AC 7Vrms	AC 7Vrms
激磁频率 (Input frequency)	10KHz	10KHz	10KHz	10KHz
变压比 (Transformation ratio)	0.5 ± 10%	0.5 ± 10%	0.5 ± 10%	0.5 ± 10%
电气误差 (Accuracy)	± 10' max	± 10' max	± 10' max	± 8' max
相位移 (Phase shift)	0° ± 10°	0° ± 10°	15° ± 3°	0° ± 10°
输入阻抗 (Input impedance)	(90 ± 14) Ω	(100 ± 15) Ω	≥ 90 Ω	(80 ± 12) Ω
输出阻抗 (Output impedance)	(390 ± 59) Ω	(440 ± 66) Ω	≤ 600 Ω	(800 ± 120) Ω
耐电压 (Dielectric strength)	AC 500Vrms 1min			
绝缘电阻 (Insulation resistance)	250MΩ MIN			
允许最大转速 (Max operating speed)	20000 rpm		15000rpm	
工作温度范围 (Operating temperature range)	-55℃ ~ +155℃			
备注 (Note)	转子内径可根据用户需求定制 (Rotor ID could be customized.)			

主要参数

main parameters

极对数 (Pole pairs)	1
激磁电压 (Input voltage)	AC 7Vrms
激磁频率 (Input frequency)	10KHz
变压比 (Transformation ratio)	0.5 ± 10%
电气误差 (Accuracy)	± 10' max
相位移 (Phase shift)	0° ± 5°
输入阻抗 (Input impedance)	(120 ± 24) Ω
输出阻抗 (Output impedance)	(350 ± 70) Ω
耐电压 (Dielectric strength)	AC 500Vrms 1min
绝缘电阻 (Insulation resistance)	250MΩ MIN
允许最大转速 (Max operating speed)	20000 rpm
工作温度范围 (Operating temperature range)	-55℃ ~ +155℃
备注 (Note)	转子内径可根据用户需求定制 (Rotor ID could be customized.)

外形及安装尺寸图

Outline(dimension:mm)

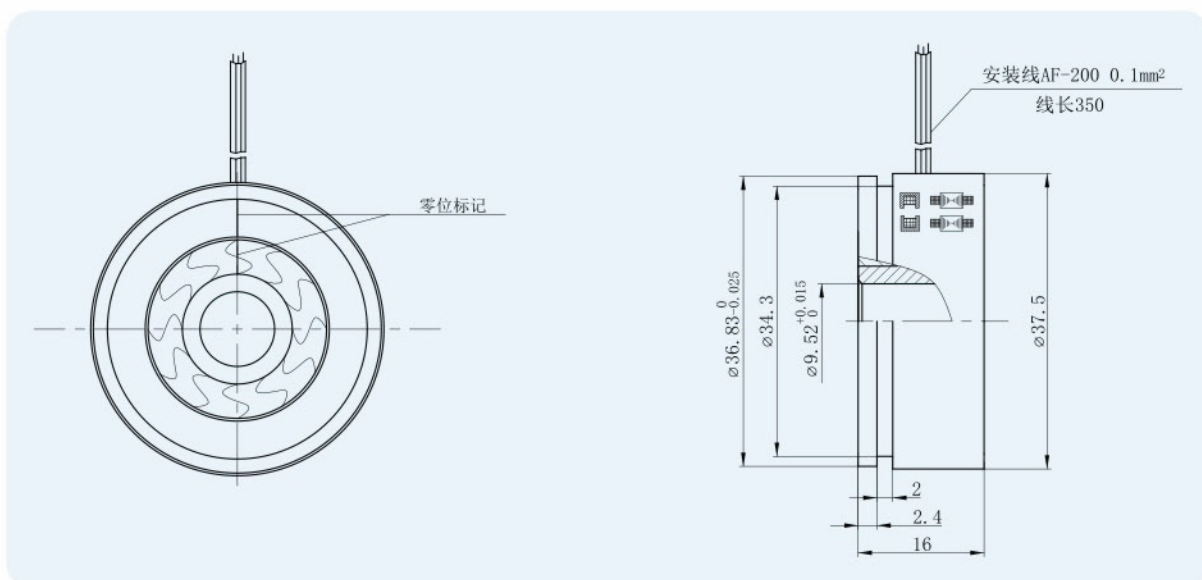

外形及安装尺寸图

Outline(dimension:mm)

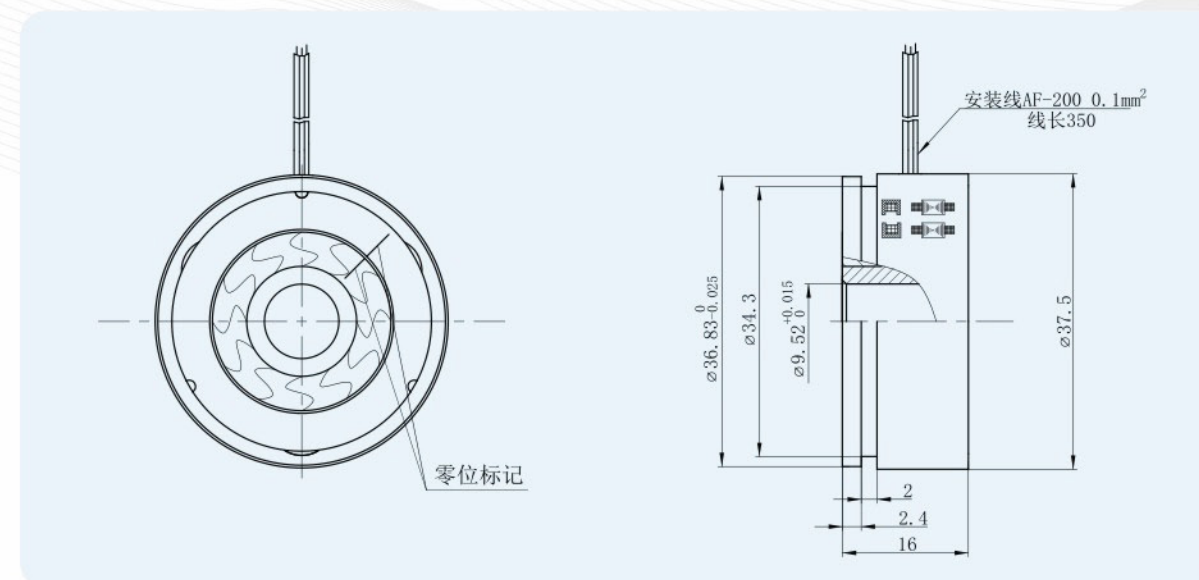

绕线式 | 36系列

Brushless resolver 36 series

J36XFW575B >>



绕线式 | 36系列

Brushless resolver 36 series

J36XFW975BX-L9 >>



主要参数 main parameters

极对数 (Pole pairs)	1
激磁电压 (Input voltage)	AC 7Vrms
激磁频率(Input frequency)	5KHz
变压比 (Transformation ratio)	0.5 ± 10%
电气误差 (Accuracy)	± 10' max
相位移 (Phase shift)	8° ± 3°
输入阻抗(Input impedance)	(95 ± 15) Ω
输出阻抗(Output impedance)	(230 ± 35) Ω
耐电压(Dielectric strength)	AC 500Vrms 1min
绝缘电阻(Insulation resistance)	250MΩ MIN
允许最大转速(Max operating speed)	20000 rpm
工作温度范围(Operating temperature range)	-55℃ ~ +155℃
备注(Note)	转子内径可根据用户需求定制 (Rotor ID could be customized.)

外形及安装尺寸图 Outline(dimension:mm)

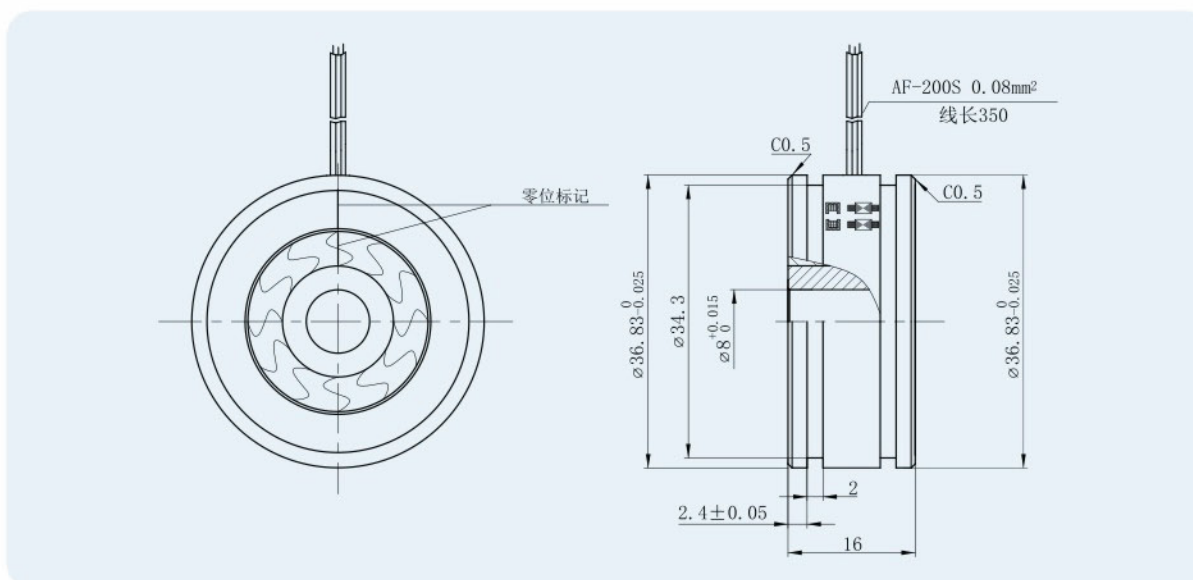

主要参数 main parameters

极对数 (Pole pairs)	1
激磁电压 (Input voltage)	AC 7Vrms
激磁频率(Input frequency)	10KHz
变压比 (Transformation ratio)	0.5 ± 10%
电气误差 (Accuracy)	± 10' max
相位移 (Phase shift)	0° ± 10°
输入阻抗(Input impedance)	(160 ± 24) Ω
输出阻抗(Output impedance)	(440 ± 66) Ω
耐电压(Dielectric strength)	AC 500Vrms 1min
绝缘电阻(Insulation resistance)	250MΩ MIN
允许最大转速(Max operating speed)	20000 rpm
工作温度范围(Operating temperature range)	-55℃ ~ +155℃
备注(Note)	转子内径可根据用户需求定制 (Rotor ID could be customized.)

外形及安装尺寸图 Outline(dimension:mm)

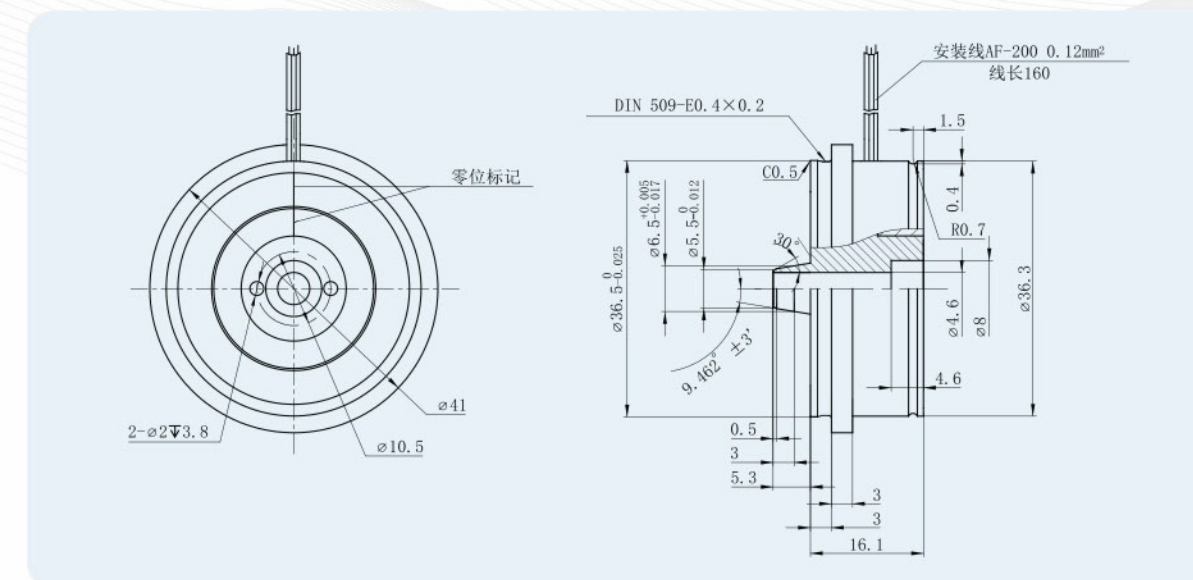

绕线式 | 52系列

Brushless resolver 52 series

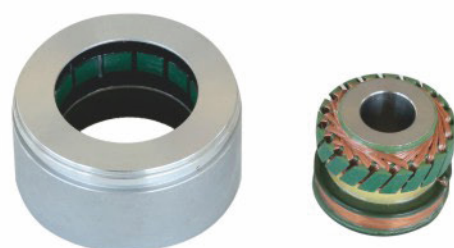

绕线式 | 52系列

Brushless resolver 52 series

J52XFW575 >>



主要参数

main parameters

型号 (Type)	J52XFW975BL	J52XFDW9752	J52XFDW9753	J52XFDW9754	J52XFDW9755
极对数 (Pole pairs)	1	2	3	4	5
激磁电压 (Input voltage)	AC 7Vrms	AC 7Vrms	AC 7Vrms	AC 7Vrms	AC 7Vrms
激磁频率(Input frequency)	10KHz	10KHz	10KHz	10KHz	10KHz
变压比 (Transformation ratio)	0.5±10%	0.5±10%	0.5±10%	0.5±10%	0.5±10%
电气误差 (Accuracy)	±10' max	±10' max	±10' max	±10' max	±10' max
相位移 (Phase shift)	9° ±3°	9° ±3°	7° ±3°	4° ±3°	0 ±10°
输入阻抗(Input impedance)	(120±18)Ω	(175±27)Ω	(170±26)Ω	(90±14)Ω	(85±13)Ω
输出阻抗(Output impedance)	(360±54)Ω	(490±74)Ω	(577±87)Ω	(530±80)Ω	(1650±248)Ω
耐电压(Dielectric strength)	AC 500V 1min				
绝缘电阻(Insulation resistance)	250MΩ MIN				
允许最大转速(Max operating speed)	20000 rpm		15000rpm	12000rpm	
工作温度范围(Operating temperature range)	-55℃ ~ +155℃				
备注(Note)	转子内径可根据用户需求定制 (Rotor ID could be customized.)				

主要参数

main parameters

极对数 (Pole pairs)	1
激磁电压 (Input voltage)	AC 7Vrms
激磁频率(Input frequency)	5KHz
变压比 (Transformation ratio)	0.5 ± 10%
电气误差 (Accuracy)	± 12' (P-P)
相位移 (Phase shift)	0° ± 3°
输入阻抗(Input impedance)	(130 ± 26)Ω
输出阻抗(Output impedance)	(500 ± 100)Ω
耐电压(Dielectric strength)	AC 500Vrms 1min
绝缘电阻(Insulation resistance)	250MΩ MIN
允许最大转速(Max operating speed)	20000 rpm
工作温度范围(Operating temperature range)	-55℃ ~ +155℃
备注(Note)	转子内径可根据用户需求定制 (Rotor ID could be customized.)

外形及安装尺寸图

Outline(dimension:mm)

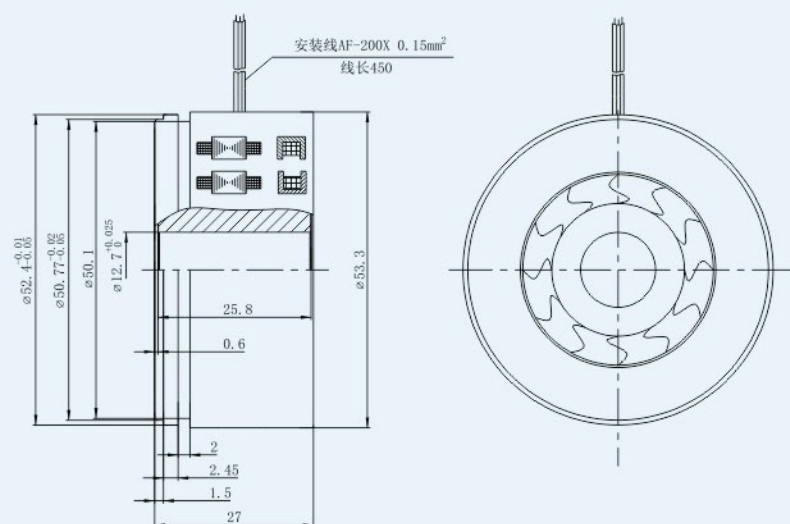

外形及安装尺寸图

Outline(dimension:mm)

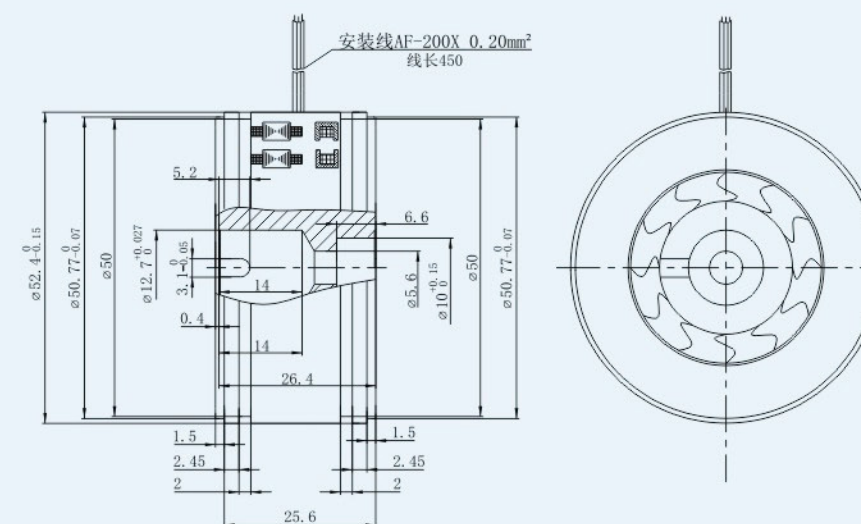

绕线式 | 55系列

Brushless resolver 55 series
J55XFW975B >>



绕线式 | 55系列

Brushless resolver 55 series
J55XFW775 >>



主要参数 main parameters

极对数 (Pole pairs)	1
激磁电压 (Input voltage)	AC 7Vrms
激磁频率(Input frequency)	10KHz
变压比 (Transformation ratio)	0.5 ± 10%
电气误差 (Accuracy)	± 10' max
相位移 (Phase shift)	9° ± 3°
输入阻抗(Input impedance)	(120 ± 18) Ω
输出阻抗(Output impedance)	(360 ± 54) Ω
耐电压(Dielectric strength)	AC 500V 1min
绝缘电阻(Insulation resistance)	250MΩ MIN
允许最大转速(Max operating speed)	20000 rpm
工作温度范围(Operating temperature range)	-55℃ ~ +155℃
备注(Note)	转子内径可根据用户需求定制 (Rotor ID could be customized.)

外形及安装尺寸图 Outline(dimension:mm)

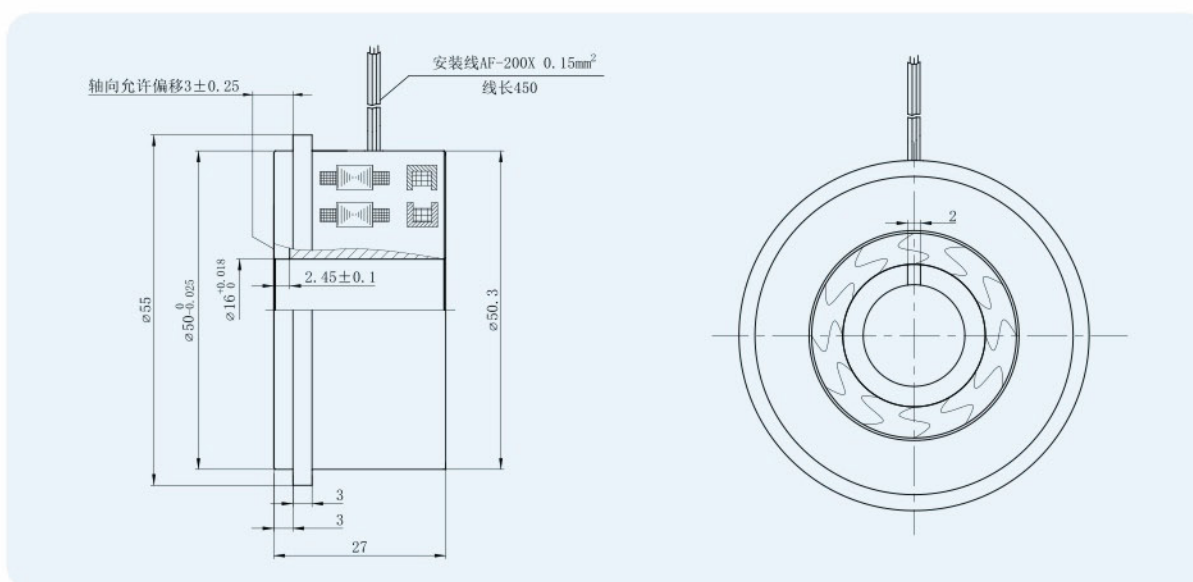

主要参数 main parameters

极对数 (Pole pairs)	1
激磁电压 (Input voltage)	AC 7Vrms
激磁频率(Input frequency)	7KHz
变压比 (Transformation ratio)	0.45 ± 10%
电气误差 (Accuracy)	± 10' max
相位移 (Phase shift)	15° ± 3°
输入阻抗(Input impedance)	(235 ± 35) Ω
输出阻抗(Output impedance)	(480 ± 72) Ω
耐电压(Dielectric strength)	AC 500V 1min
绝缘电阻(Insulation resistance)	250MΩ MIN
允许最大转速(Max operating speed)	20000 rpm
工作温度范围(Operating temperature range)	-55℃ ~ +155℃
备注(Note)	转子内径可根据用户需求定制 (Rotor ID could be customized.)

外形及安装尺寸图 Outline(dimension:mm)

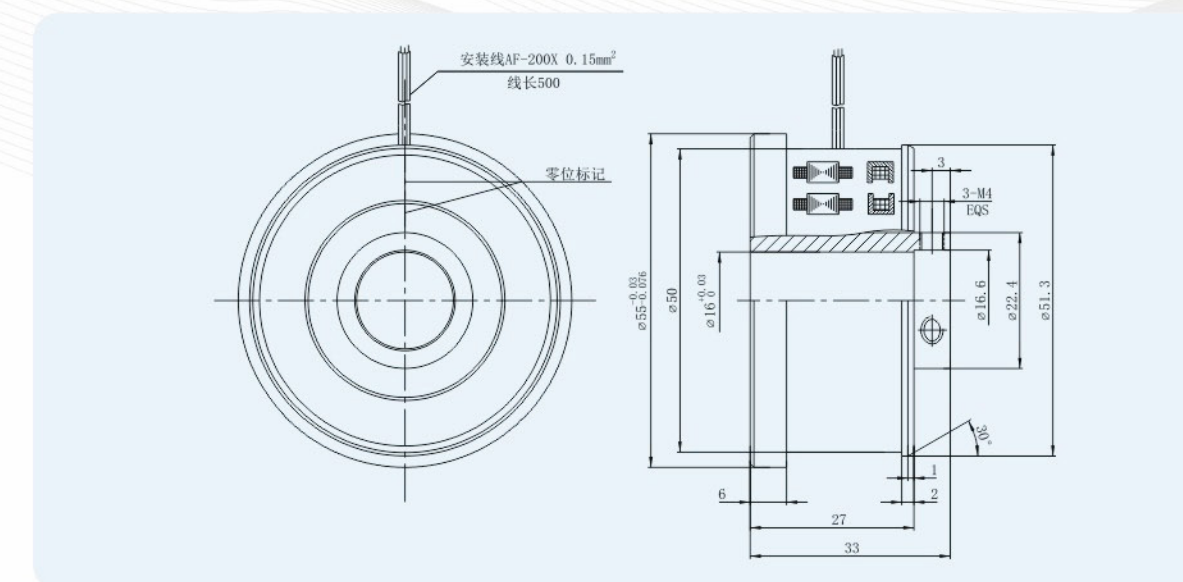

绕线式 | 68系列

Brushless resolver 68 series

J68XFW975 >>



绕线式 | 80系列

Brushless resolver 80 series

80XFW975A >>



主要参数 main parameters

极对数 (Pole pairs)	1
激磁电压 (Input voltage)	AC 7Vrms
激磁频率 (Input frequency)	10KHz
变压比 (Transformation ratio)	0.5 ± 10%
电气误差 (Accuracy)	± 10' max
相位移 (Phase shift)	9° ± 3°
输入阻抗 (Input impedance)	(120 ± 18) Ω
输出阻抗 (Output impedance)	(360 ± 54) Ω
耐电压 (Dielectric strength)	AC 500V 1min
绝缘电阻 (Insulation resistance)	250MΩ MIN
允许最大转速 (Max operating speed)	15000 rpm
工作温度范围 (Operating temperature range)	-55℃ ~ +155℃
备注 (Note)	转子内径可根据用户需求定制 (Rotor ID could be customized.)

主要参数 main parameters

极对数 (Pole pairs)	1
激磁电压 (Input voltage)	AC 7Vrms
激磁频率 (Input frequency)	10KHz
变压比 (Transformation ratio)	0.5 ± 10%
电气误差 (Accuracy)	± 10' max
相位移 (Phase shift)	-23° ± 3°
输入阻抗 (Input impedance)	(140 ± 21) Ω
输出阻抗 (Output impedance)	(450 ± 90) Ω
耐电压 (Dielectric strength)	AC 500V 1min
绝缘电阻 (Insulation resistance)	250MΩ MIN
允许最大转速 (Max operating speed)	20000 rpm
工作温度范围 (Operating temperature range)	-55℃ ~ +155℃
备注 (Note)	转子内径可根据用户需求定制 (Rotor ID could be customized.)

外形及安装尺寸图 Outline (dimension: mm)

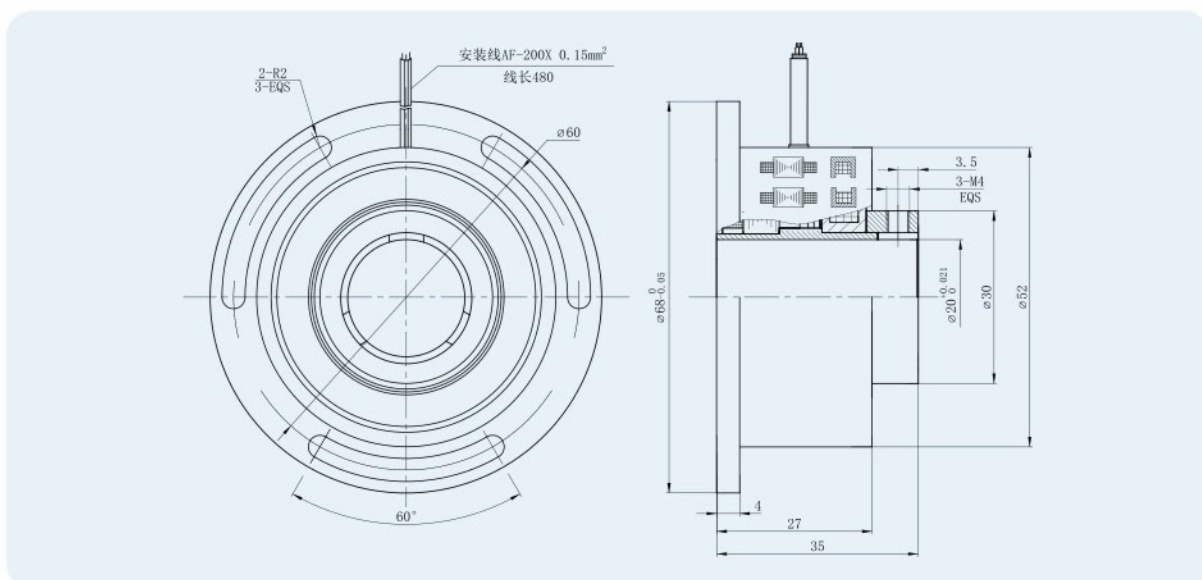

外形及安装尺寸图 Outline (dimension: mm)

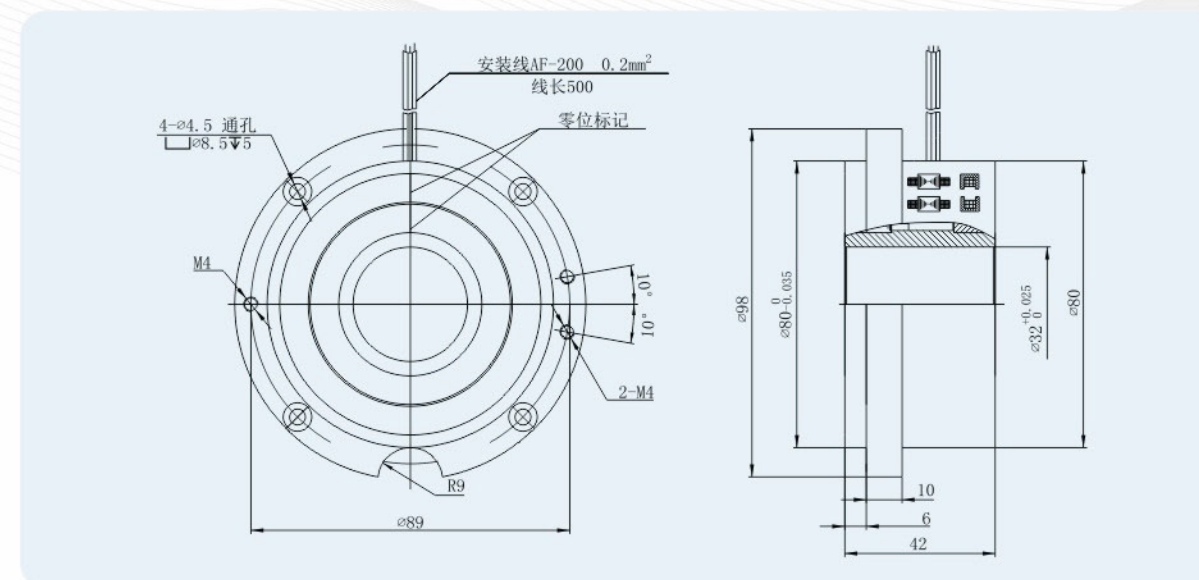

绕线式 | 86系列

Brushless resolver 86 series

86XFW975 >>

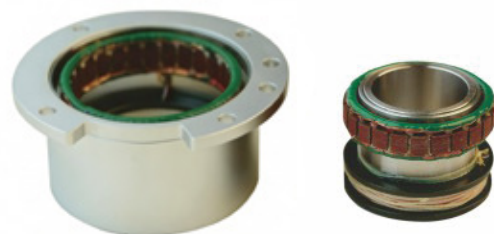

绕线式 | 110系列

Brushless resolver 110 series

110XFW975 >>



主要参数 main parameters

极对数 (Pole pairs)	1
激磁电压 (Input voltage)	AC 7Vrms
激磁频率(Input frequency)	10KHz
变压比 (Transformation ratio)	0.5 ± 10%
电气误差 (Accuracy)	± 10' max
相位移 (Phase shift)	-22° ± 3°
输入阻抗(Input impedance)	(116 ± 17) Ω
输出阻抗(Output impedance)	(400 ± 60) Ω
耐电压(Dielectric strength)	AC 500V 1min
绝缘电阻(Insulation resistance)	250MΩ MIN
允许最大转速(Max operating speed)	20000 rpm
工作温度范围(Operating temperature range)	-55℃ ~ +155℃
备注(Note)	转子内径可根据用户需求定制 (Rotor ID could be customized.)

主要参数 main parameters

极对数 (Pole pairs)	1
激磁电压 (Input voltage)	AC 7Vrms
激磁频率(Input frequency)	10KHz
变压比 (Transformation ratio)	0.5 ± 10%
电气误差 (Accuracy)	± 10' max
相位移 (Phase shift)	-22° ± 3°
输入阻抗(Input impedance)	(225 ± 34) Ω
输出阻抗(Output impedance)	(576 ± 86) Ω
耐电压(Dielectric strength)	AC 500V 1min
绝缘电阻(Insulation resistance)	250MΩ MIN
允许最大转速(Max operating speed)	20000 rpm
工作温度范围(Operating temperature range)	-55℃ ~ +155℃
备注(Note)	转子内径可根据用户需求定制 (Rotor ID could be customized.)

外形及安装尺寸图 Outline(dimension:mm)

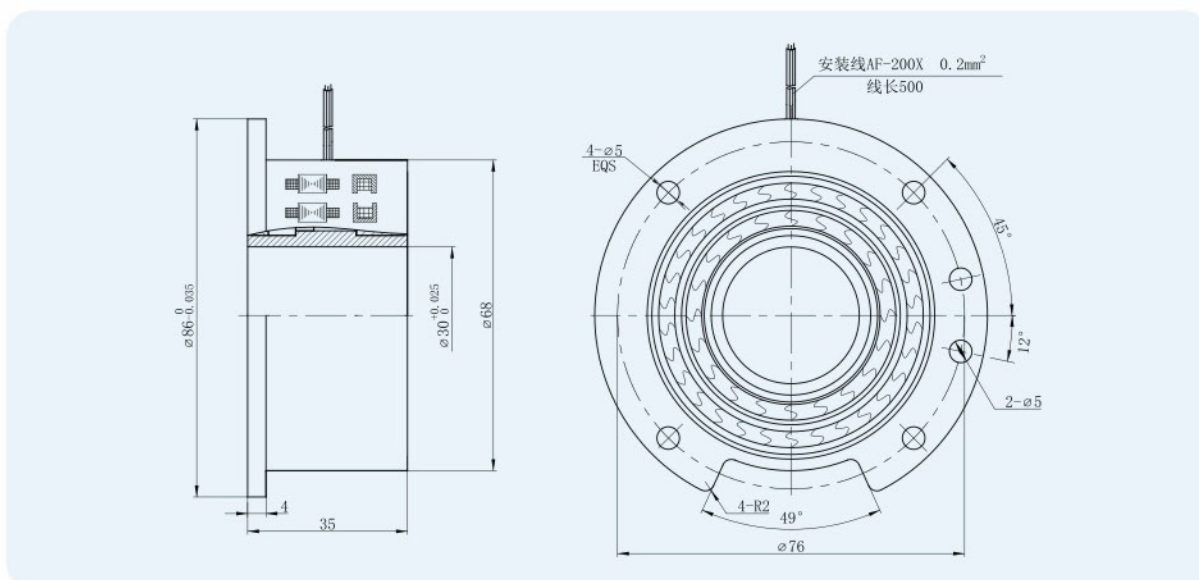

外形及安装尺寸图 Outline(dimension:mm)

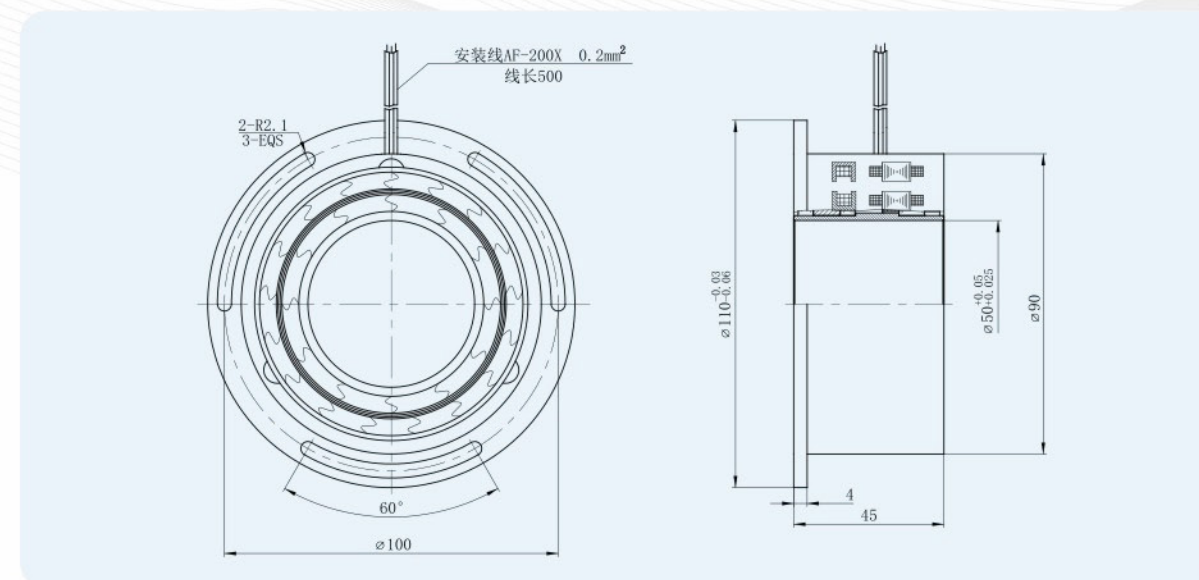

绕线式 | 140系列

Brushless resolver 140 series

140XFW975 >>



主要参数	main parameters
极对数 (Pole pairs)	1
激磁电压 (Input voltage)	AC 7Vrms
激磁频率(Input frequency)	10KHz
变压比 (Transformation ratio)	0.5 ± 10%
电气误差 (Accuracy)	± 10' max
相位移 (Phase shift)	-22° ± 3°
输入阻抗(Input impedance)	(100 ± 15) Ω
输出阻抗(Output impedance)	(580 ± 87) Ω
耐电压(Dielectric strength)	AC 500V 1min
绝缘电阻(Insulation resistance)	250MΩ MIN
允许最大转速(Max operating speed)	20000 rpm
工作温度范围(Operating temperature range)	-55℃ ~ +155℃
备注(Note)	转子内径可根据用户需求定制 (Rotor ID could be customized.)

外形及安装尺寸图 Outline(dimension:mm)

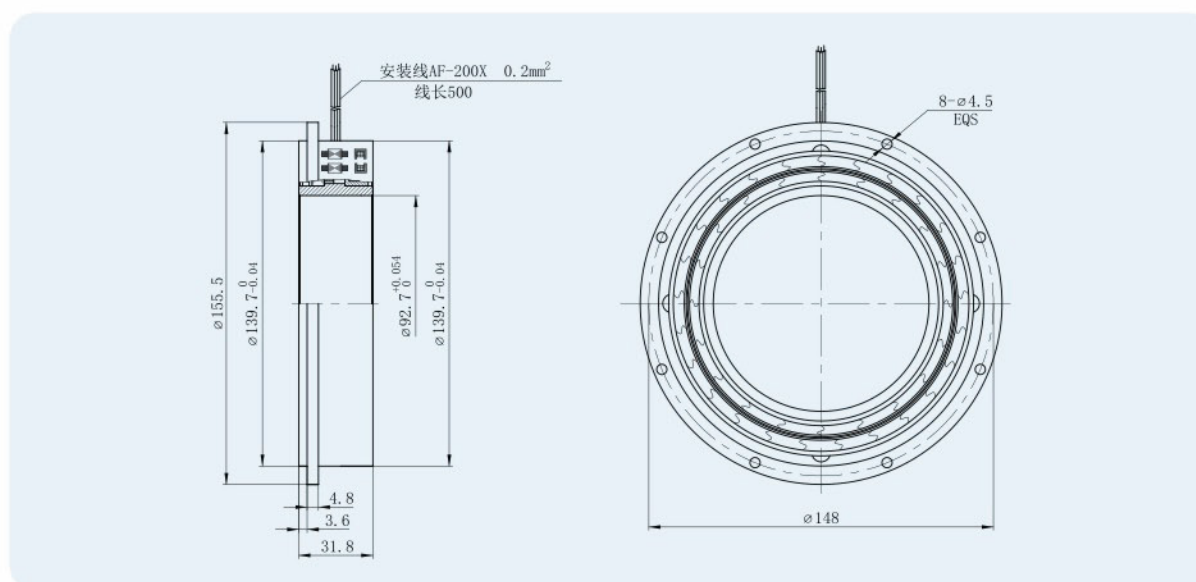

绕线式 | 160系列

Brushless resolver 160 series

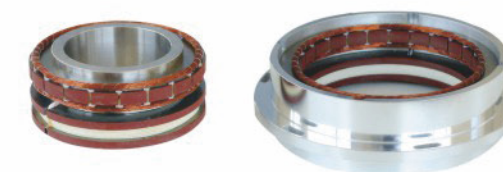

主要参数	main parameters	
型号 (Type)	160XZW001	160XFDW9756
极对数 (Pole pairs)	1	6
激磁电压 (Input voltage)	AC 7Vrms	AC 7Vrms
激磁频率(Input frequency)	10KHz	10KHz
变压比 (Transformation ratio)	0.5 ± 10%	0.5 ± 10%
电气误差 (Accuracy)	± 10' max	± 3' max
相位移 (Phase shift)	28.8° ± 3°	0° ± 15°
输入阻抗(Input impedance)	(150 ± 23) Ω	(115 ± 17) Ω
输出阻抗(Output impedance)	(980 ± 147) Ω	(820 ± 123) Ω
耐电压(Dielectric strength)	AC 500V 1min	AC 500V 1min
绝缘电阻(Insulation resistance)	250MΩ MIN	250MΩ MIN
允许最大转速(Max operating speed)	20000 rpm	10000 rpm
工作温度范围(Operating temperature range)	-55℃ ~ +155℃	-55℃ ~ +155℃
备注(Note)	转子内径可根据用户需求定制 (Rotor ID could be customized.)	

外形及安装尺寸图 Outline(dimension:mm)

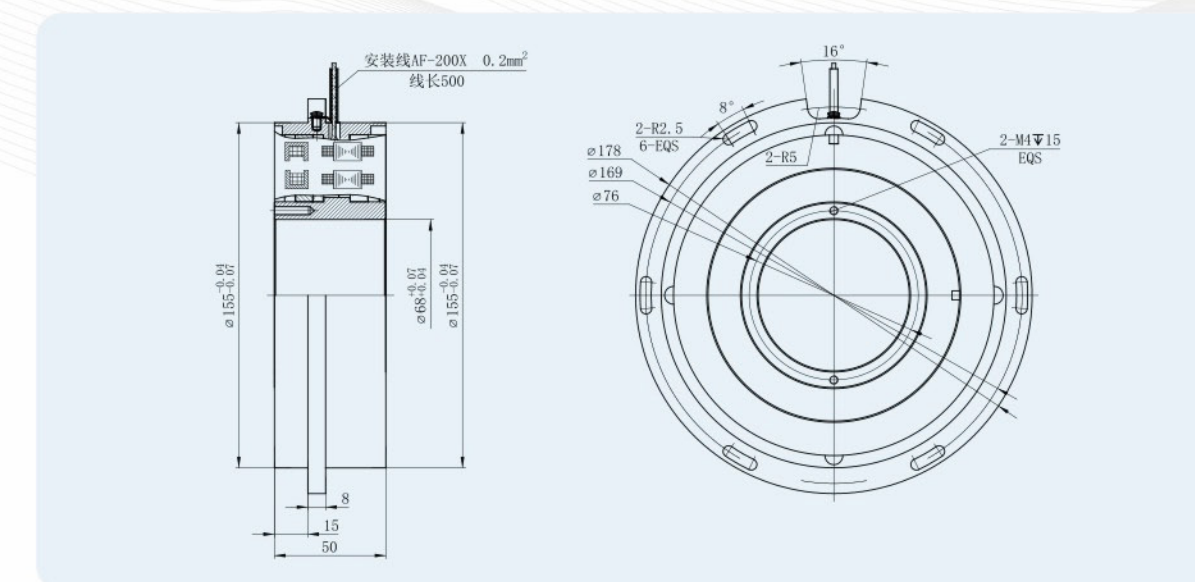

双通道旋变 | 45 系列

Two speed resolver 45 series

J45XFS2458 >>



双通道旋变 | 60 系列

Two speed resolver 60 series

J60XFS002 >>

主要参数 main parameters

极对数 (Pole pairs)		1:8
激磁电压 (Input voltage)		AC 4Vrms
激磁频率(Input frequency)		2KHz
变压比 (Transformation ratio)		0.5 ± 10%
电气误差 (Accuracy)	粗机	± 30' max
	精机	± 2' max
相位移 (Phase shift)	粗机	0° ± 20°
	精机	0° ± 45°
输入阻抗(Input impedance)	粗机精机并联	(75 ± 15) Ω
耐电压(Dielectric strength)		AC 250V 1min
绝缘电阻(Insulation resistance)		100MΩ MIN
允许最大转速(Max operating speed)		2500 rpm
工作温度范围(Operating temperature range)		-55℃ ~ +155℃
备注(Note)	转子内径可根据用户需求定制 (Rotor ID could be customized.)	

主要参数 main parameters

极对数 (Pole pairs)		1:16
激磁电压 (Input voltage)		AC 26Vrms
激磁频率(Input frequency)		2400Hz
变压比 (Transformation ratio)		0.454 ± 10%
电气误差 (Accuracy)	粗机	± 30' max
	精机	± 25' max
相位移 (Phase shift)	粗机	0° ± 15°
	精机	0° ± 25°
输入阻抗(Input impedance)	粗机	(1450 ± 218) Ω
	精机	(450 ± 68) Ω
输出阻抗(Output impedance)	粗机	(525 ± 79) Ω
	精机	(620 ± 93) Ω
耐电压(Dielectric strength)		AC 500V 1min
绝缘电阻(Insulation resistance)		250MΩ MIN
允许最大转速(Max operating speed)		2250 rpm
工作温度范围(Operating temperature range)		-55℃ ~ +155℃
备注(Note)	转子内径可根据用户需求定制 (Rotor ID could be customized.)	

外形及安装尺寸图 Outline(dimension:mm)

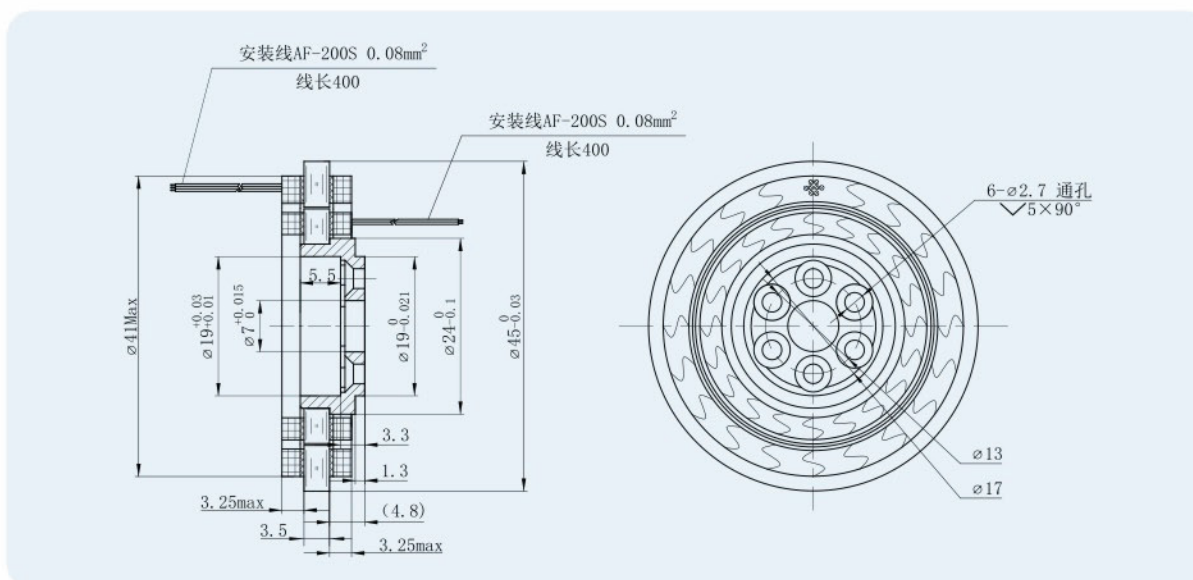

外形及安装尺寸图 Outline(dimension:mm)

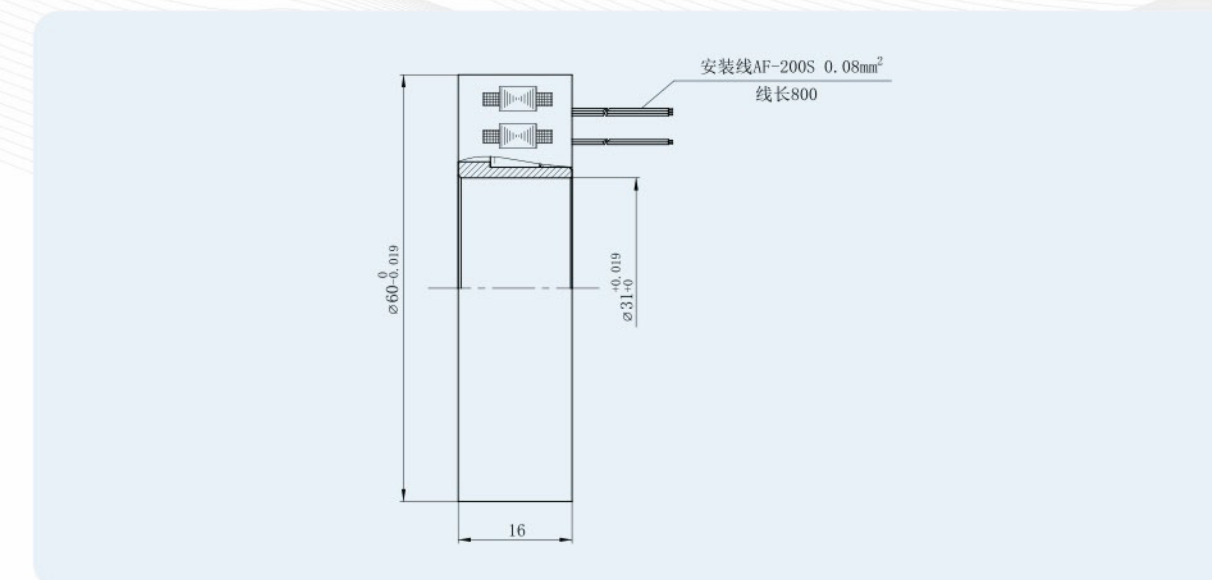

双通道旋变 | 80 系列

Two speed resolver 80 series

J80XFSW54532A >>



双通道旋变 | 90 系列

Two speed resolver 90 series

J90XFS24532 >>

主要参数 | main parameters

极对数 (Pole pairs)		1:32
激磁电压 (Input voltage)		AC 4Vrms
激磁频率 (Input frequency)		5KHz
变压比 (Transformation ratio)		0.5 ± 10%
电气误差 (Accuracy)	粗机	± 30' max
	精机	± 30" max
相位移 (Phase shift)	粗机	7° ± 3°
	精机	24° ± 3°
输入阻抗 (Input impedance)	粗机	(63 ± 9) Ω
	精机	(63 ± 9) Ω
输出阻抗 (Output impedance)	粗机	(510 ± 77) Ω
	精机	(730 ± 110) Ω
耐电压 (Dielectric strength)		AC 500V 1min
绝缘电阻 (Insulation resistance)		250MΩ MIN
允许最大转速 (Max operating speed)		2250 rpm
工作温度范围 (Operating temperature range)		-55°C ~ +155°C
备注 (Note)	转子内径可根据用户需求定制 (Rotor ID could be customized.)	

外形及安装尺寸图 | Outline (dimension:mm)

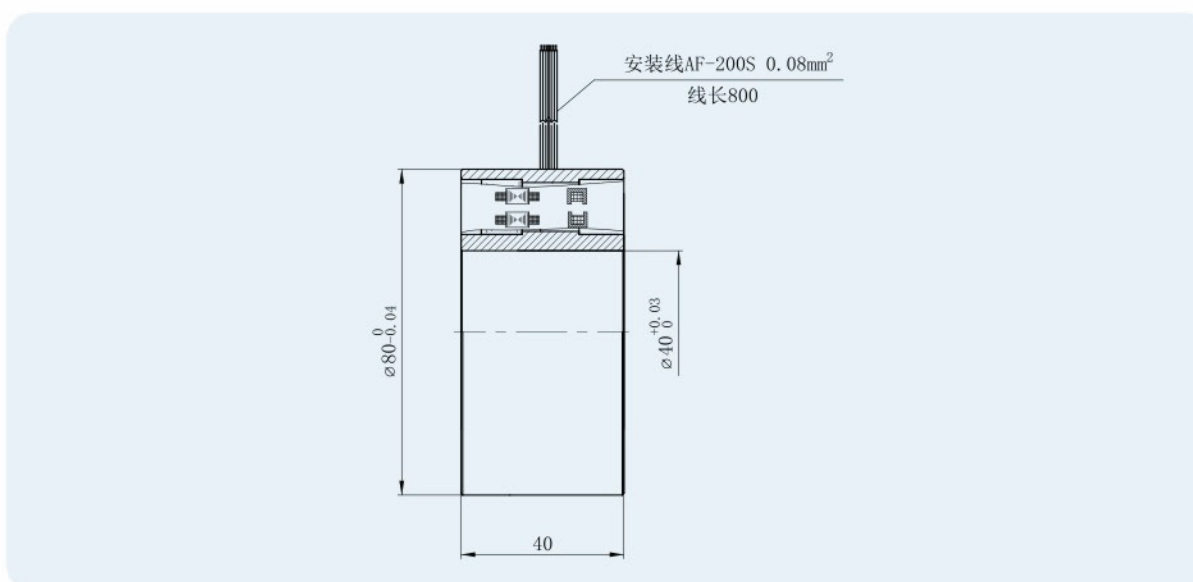

主要参数 | main parameters

极对数 (Pole pairs)		1:32
激磁电压 (Input voltage)		AC 4Vrms
激磁频率 (Input frequency)		2KHz
变压比 (Transformation ratio)		0.5 ± 10%
电气误差 (Accuracy)	粗机	± 25' max
	精机	± 15" max
相位移 (Phase shift)	粗机	0° ± 20°
	精机	0° ± 30°
输入阻抗 (Input impedance)	粗机	≥ 1500 Ω
	精机	≥ 150 Ω
输出阻抗 (Output impedance)	粗机	≤ 1500 Ω
	精机	≤ 1000 Ω
耐电压 (Dielectric strength)		AC 500V 1min
绝缘电阻 (Insulation resistance)		250MΩ MIN
允许最大转速 (Max operating speed)		2000 rpm
工作温度范围 (Operating temperature range)		-55°C ~ +155°C
备注 (Note)	转子内径可根据用户需求定制 (Rotor ID could be customized.)	

外形及安装尺寸图 | Outline (dimension:mm)

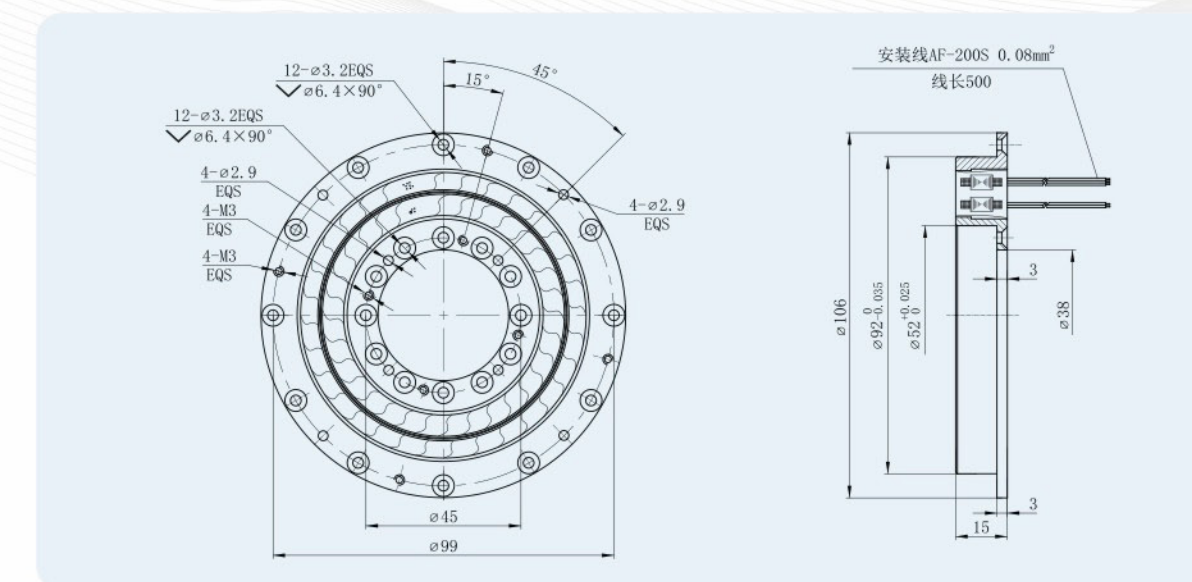

双通道旋变 | 106 系列

Two speed resolver 106 series

J106XFS02658 >>

双通道旋变 | 128 系列

Two speed resolver 128 series

J128XFS001 >>



主要参数 main parameters

极对数 (Pole pairs)		1:8
激磁电压 (Input voltage)		AC 26Vrms
激磁频率(Input frequency)		400Hz
变压比 (Transformation ratio)		0.461 ± 10%
电气误差 (Accuracy)	粗机	± 30' max
	精机	± 1' max
相位移 (Phase shift)	粗机	8° ± 3°
	精机	30° ± 3°
输入阻抗(Input impedance)	粗机	(3270 ± 491) Ω
	精机	(390 ± 59) Ω
输出阻抗(Output impedance)	粗机	(1100 ± 165) Ω
	精机	(240 ± 36) Ω
耐电压(Dielectric strength)		AC 500V 1min
绝缘电阻(Insulation resistance)		250MΩ MIN
允许最大转速(Max operating speed)		750 rpm
工作温度范围(Operating temperature range)		-55°C ~ +155°C
备注(Note)	转子内径可根据用户需求定制 (Rotor ID could be customized.)	

主要参数 main parameters

极对数 (Pole pairs)		1:16
激磁电压 (Input voltage)		AC 3.8Vrms
激磁频率(Input frequency)		2400Hz
变压比 (Transformation ratio)		0.526 ± 10%
电气误差 (Accuracy)	粗机	± 10' max
	精机	± 15" max
相位移 (Phase shift)	粗机	8° ± 3°
	精机	17° ± 3°
输入阻抗(Input impedance)	粗机	(1700 ± 255) Ω
	精机	(290 ± 44) Ω
输出阻抗(Output impedance)	粗机	(430 ± 65) Ω
	精机	(190 ± 29) Ω
耐电压(Dielectric strength)		AC 500V 1min
绝缘电阻(Insulation resistance)		250MΩ MIN
允许最大转速(Max operating speed)		2250 rpm
工作温度范围(Operating temperature range)		-55°C ~ +155°C
备注(Note)	转子内径可根据用户需求定制 (Rotor ID could be customized.)	

外形及安装尺寸图 Outline(dimension:mm)

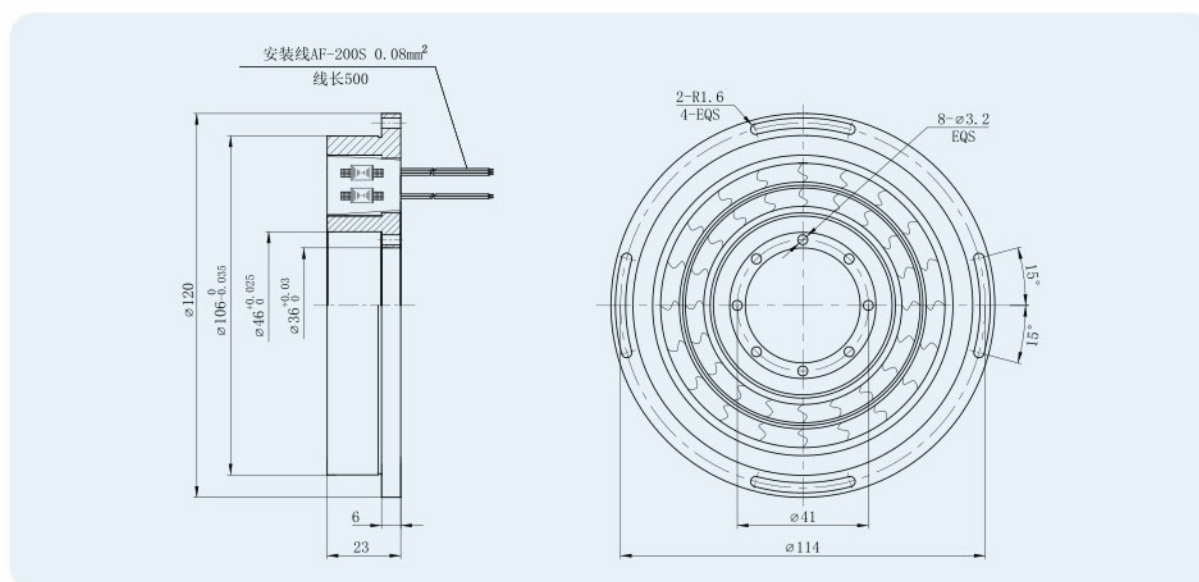

外形及安装尺寸图 Outline(dimension:mm)

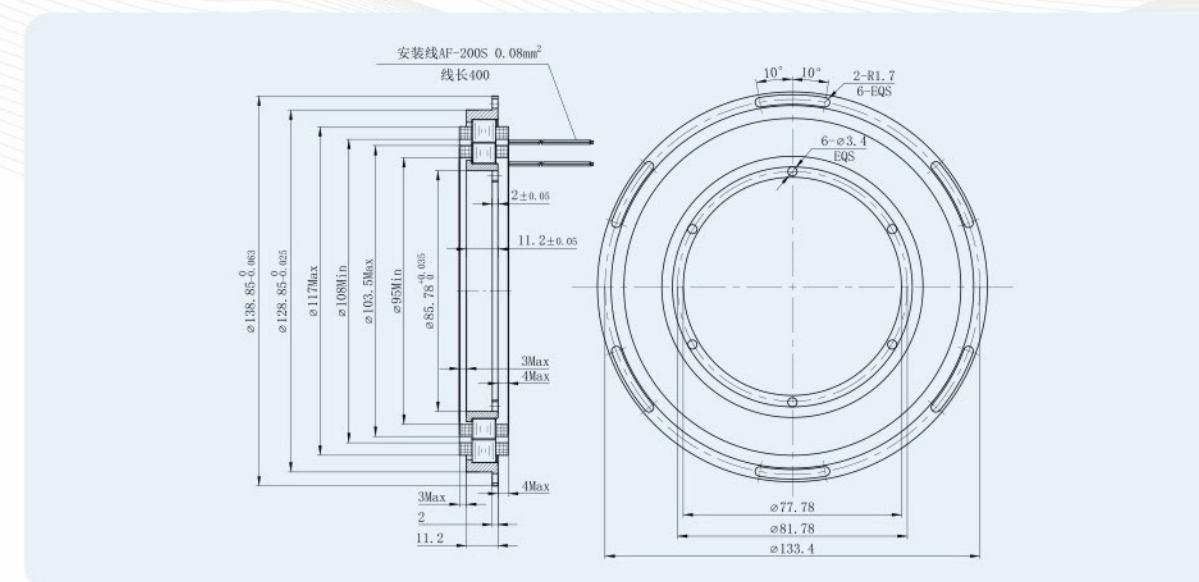

双通道旋变 | 158系列

Two speed resolver 158 series

J158XFS002 >>



双通道旋变 | 168系列

Two speed resolver 168 series

J168XFSW24516 >>

主要参数 main parameters

极对数 (Pole pairs)		1:16
激磁电压 (Input voltage)		AC 26Vrms
激磁频率(Input frequency)		400Hz
变压比 (Transformation ratio)		0.461 ± 10%
电气误差 (Accuracy)	粗机	± 20' max
	精机	± 15" max
相位移 (Phase shift)	粗机	17° ± 3°
	精机	43° ± 3°
输入阻抗(Input impedance)	粗机	(2170 ± 326) Ω
	精机	(220 ± 33) Ω
输出阻抗(Output impedance)	粗机	(1310 ± 197) Ω
	精机	(470 ± 71) Ω
耐电压(Dielectric strength)		AC 500V 1min
绝缘电阻(Insulation resistance)		250MΩ MIN
允许最大转速(Max operating speed)		300 rpm
工作温度范围(Operating temperature range)		-55°C ~ +155°C
备注(Note)	转子内径可根据用户需求定制 (Rotor ID could be customized.)	

外形及安装尺寸图 Outline(dimension:mm)

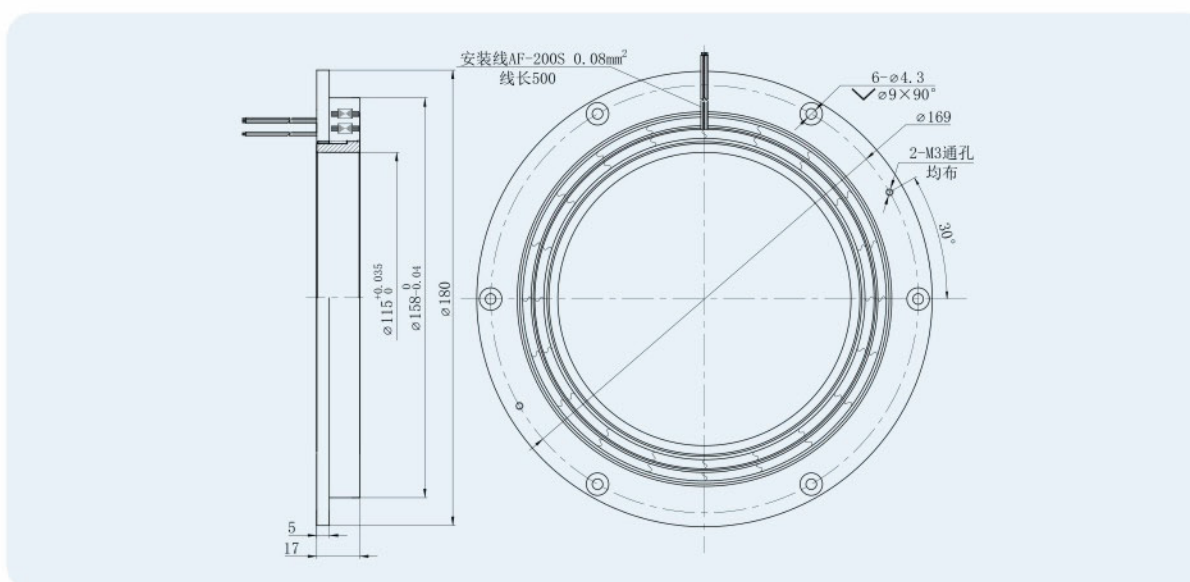

主要参数 main parameters

极对数 (Pole pairs)		1:16
激磁电压 (Input voltage)		AC 3.8Vrms
激磁频率(Input frequency)		2400Hz
变压比 (Transformation ratio)		0.526 ± 10%
电气误差 (Accuracy)	粗机	± 30' max
	精机	± 25" max
相位移 (Phase shift)	粗机	20° ± 3°
	精机	30° ± 3°
输入阻抗(Input impedance)	粗机	(130 ± 20) Ω
	精机	(130 ± 20) Ω
输出阻抗(Output impedance)	粗机	(1200 ± 180) Ω
	精机	(750 ± 113) Ω
耐电压(Dielectric strength)		AC 500V 1min
绝缘电阻(Insulation resistance)		250MΩ MIN
允许最大转速(Max operating speed)		1500 rpm
工作温度范围(Operating temperature range)		-55°C ~ +155°C
备注(Note)	转子内径可根据用户需求定制 (Rotor ID could be customized.)	

外形及安装尺寸图 Outline(dimension:mm)

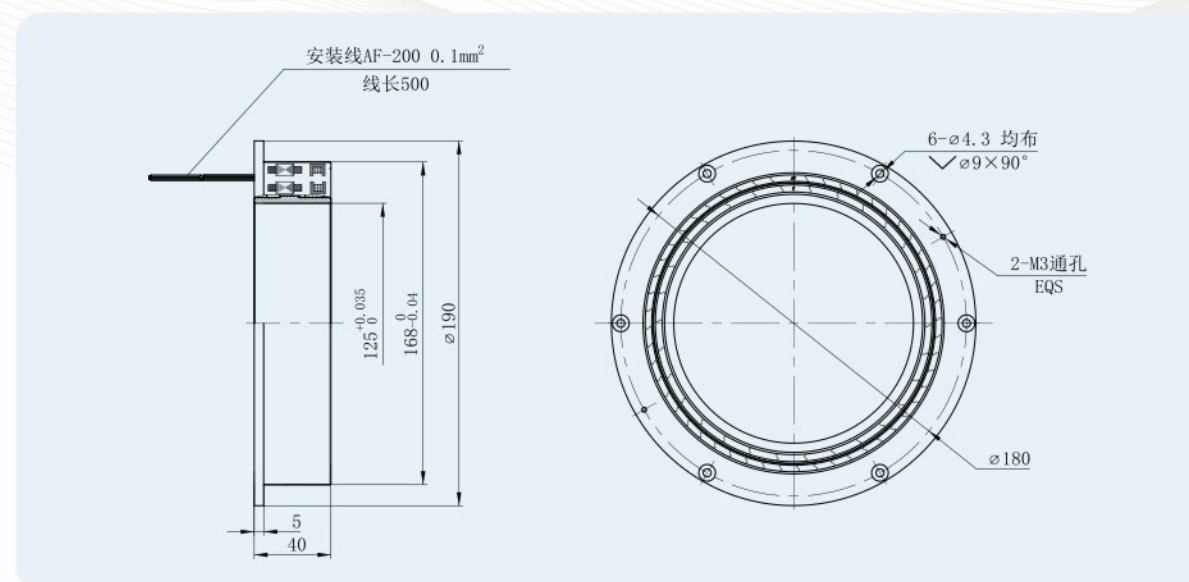

一体式 | 51 系列

Fabricated resolver 51 series



一体式 | 58 系列

Fabricated resolver 58 series

J58XFW975C >>



主要参数 main parameters

型号 (Type)	J51XFW975	J51XFDW9754
极对数 (Pole pairs)	1	4
激磁电压 (Input voltage)	AC 2.4Vrms	AC 2.4Vrms
激磁频率 (Input frequency)	10KHz	10KHz
变压比 (Transformation ratio)	0.5 ± 10%	0.5 ± 10%
电气误差 (Accuracy)	± 10' max	± 5' max
相位移 (Phase shift)	0° ± 10°	0° ± 5°
输入阻抗 (Input impedance)	(100 ± 15) Ω	(160 ± 32) Ω
输出阻抗 (Output impedance)	(370 ± 56) Ω	(1300 ± 260) Ω
耐电压 (Dielectric strength)	AC 500Vrms 1min	AC 500Vrms 1min
绝缘电阻 (Insulation resistance)	250MΩ MIN	250MΩ MIN
工作温度范围 (Operating temperature range)	-40℃ ~ +120℃	-40℃ ~ +120℃

主要参数 main parameters

极对数 (Pole pairs)	1
激磁电压 (Input voltage)	AC 7Vrms
激磁频率 (Input frequency)	10KHz
变压比 (Transformation ratio)	0.5 ± 10%
电气误差 (Accuracy)	± 12' (P-P)
相位移 (Phase shift)	-3° ± 3°
输入阻抗 (Input impedance)	(130 ± 20) Ω
输出阻抗 (Output impedance)	(325 ± 30) Ω
耐电压 (Dielectric strength)	AC 500Vrms 1min
绝缘电阻 (Insulation resistance)	250MΩ MIN
工作温度范围 (Operating temperature range)	-30℃ ~ +95℃

外形及安装尺寸图 Outline (dimension:mm)

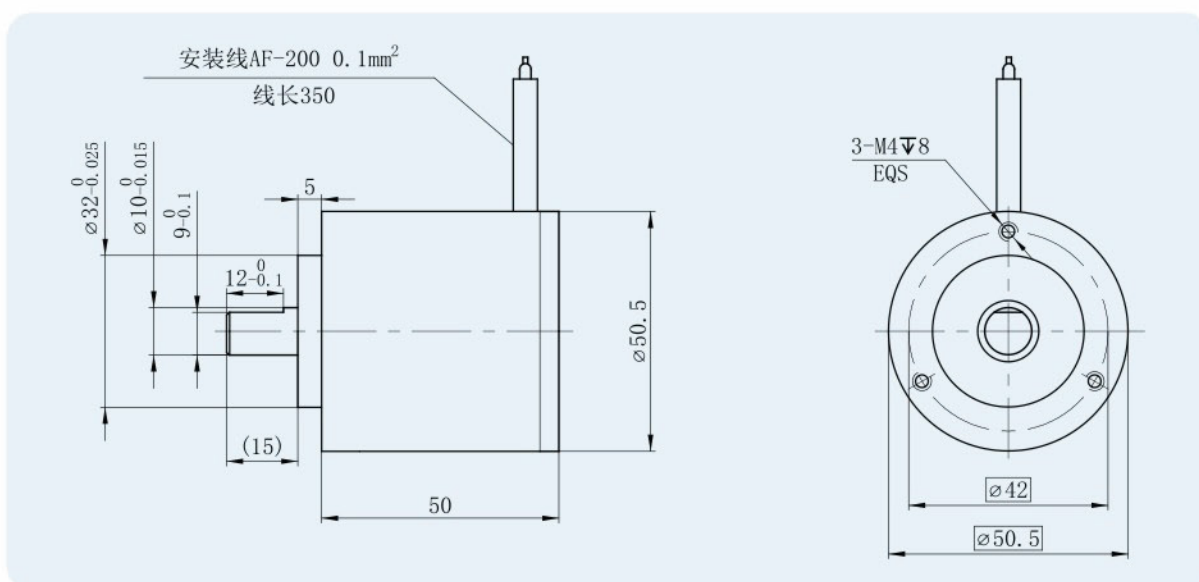

外形及安装尺寸图 Outline (dimension:mm)

